

SEITRON AMERICAS Inc. - ALL RIGHTS RESERVED -

Any reproduction, in whole or in part, of this document by any means (including photocopying or storing it in any electronic device) and the transmission of the latter to third parties in any way, including electronically, is strictly forbidden without the prior written approval by SEITRON AMERICAS Inc.

Important information	07
Information about this manual	07
Danger levels and other symbols	07
Safety	08
Proper use of the product	08
Improper use of the product	08
ELECTRICAL CONNECTIONS	09
Electrical connections	09
Wiring the signal lines	11
Connection of the serial port RS485 half duplex according to MODBUS® RTU	11
Analog outputs through 37 poles connector	12
CONNECTIONS	15
Connection to PC via supplied USB cable	15
Connection to PC via Ethernet cable	16
Wiring diagram - Back panel	17
Remote air intake filter assembly	17
Junctions assembly - Optional	18
Wiring diagram - Back cover	19
Connection to the nitrogen/synthetic air cylinder	20
Pitot tube and Flue Gas sampling probe connection	21
Pitot tube	22
Features of the smoke suction line	23
Features of the heated smoke suction line (for the measurement of NO _x - SO _x)	24
Combustion air temperature probe	25
Draft measurement	25
Remote air suction spots	25
PRODUCT USE	27
Technical features	27
Product features	29
General overview of the Analyzer	29
Working principle	30
CO dilution	30
Fuel types	30
Peltier module condensation assembly (Cooler)	31
Remote condensate sink	31
External dust filters	31
Dust filter for the NDIR bench protection	31
Remote air intake	31
Remote air intake connected in Nitrogen or Synthetic air	31
Pressure sensor, piezoelectric, temperature compensated	31
Smoke suction pump	32
Condensate sink pump	32
Draft measurement with sensor automatic autozero	32
Temperature measurements	32
Calculating total carbon	32
Autozero difference in air, nitrogen and synthetic air	32
Available software	32
External size	33
Measurement and Accuracy Ranges	34
Components description	36
Front cover	36
Back panel	38
Startup	40
Preliminary operations	40
Instrument power supply	40
Warning	40

Infrared bench	107
Infrared bench for heat treatment	107
Troubleshooting	108
Troubleshooting guide	108
Spare parts and servicing	110
Spare parts	110
Accessories	110
Service centers	111
MAINTENANCE	112
Routine maintenance	112
Scheduled maintenance	112
Cleaning external dust filters	113
Replacement of external anti-pollution filter on IR line	114
Replacement of external anti-cleaning filter on remote air intake	114
Fuse replacement	115
Firmware update	116
ANNEX	
Annex A - Fuel Coefficients and formulas	119
Annex B - Law directions	120
Annex C - Optional measures list	121
WARRANTY	123



WARNING

We encourage you to consult the owner's manual in its most up-to-date version by downloading it from the website www.seitron.com.



1.1 Information about this manual

- This manual describes the operation and the characteristics and the maintenance of the Combustion Analyzer S9000-RACK.
- Read this operation and maintenance manual before using the device. The operator must be familiar with the manual and follow the instructions carefully.
- This use and maintenance manual is *subject to change due to technical improvements - the manufacturer assumes no responsibility for any mistakes or misprints.*

1.2 Danger levels and other symbols

Symbol	Meaning	Comments
--------	---------	----------



Read information carefully and prepare safety appropriate action!

To prevent any danger from personnel or other goods. Disobey of this manual may cause danger to personnel, the plant or the environment and may lead to liability loss.

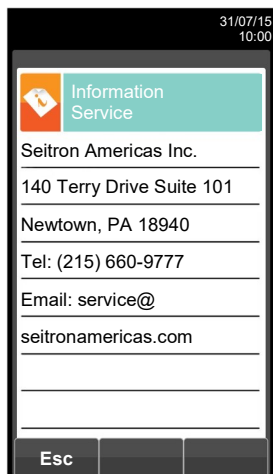

Information on LCD



Ensure correct disposal

Dispose of the battery pack at the end of its working life only at the dedicated collecting bin.

The customer takes care, on his own costs, that at the end of its working life the product is collected separately and it gets correctly recycled.

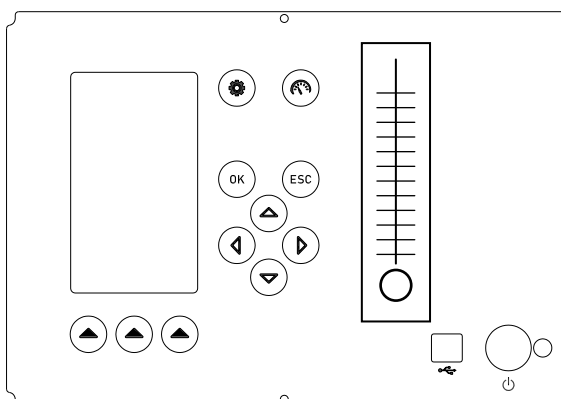

Touch keyboard with main control functions.

1.3 Safety

1.3.1 Proper use of the product

This chapter describes the areas of application for which the S9000-RACK is intended.

All products of the series S9000-RACK are stationary measuring devices, in a 19" metal case, for rack mounting; these instruments are capable of measuring gas in the following plants:

- Boilers (fuel oil, gas, wood, coal)
- Low-temperature condensing boilers
- Gas heaters
- Emissions control measurements
- Installations compliance tests
- Gas turbines
- Gas engines
- Furnaces and boilers technical assistance
- Technical assistance in industrial heating systems
- Process control

1.3.2 Improper use of the product

The use of S9000-RACK in application areas other than those specified in Section 1.3.1 "Proper use of the product" is to be considered at the operator's risk and the manufacturer assumes no responsibility for the loss damage or costs that may result. It is compulsory to read and pay attention to the instructions in this use and maintenance manual.

S9000-RACK should not be used:

- as an alarm device for safety purposes
- in classified zones with explosion risk (ATEX or equivalent)

2.1 Electrical connections



WARNING

- CONNECT THE DEVICE TO MAINS POWER THROUGH A BI-POLAR SWITCH COMPLYING WITH CURRENT STANDARDS AND WITH CONTACTS APERTURE DISTANCE OF AT LEAST 3 MM IN EACH POLE.
- THE INSTALLATION AND THE ELECTRICAL WIRING OF THE DEVICE MUST BE PERFORMED BY QUALIFIED TECHNICIAN AND IN CONFORMITY WITH CURRENT STANDARDS.
- THE MINIMUM CROSS SECTION OF THE POWER CABLE SINGLE CONDUCTORS MUST BE 1 mm². THE CROSS SECTION OF THE PE CONDUCTOR MUST NOT BE SMALLER THAN CONDUCTORS L AND N CROSS SECTION.
- THE CABLE MUST BE SUITABLE FOR A MINIMUM TEMPERATURE OF 70 °C (158 °F) AND MUST BE HOMOLOGATED FOR THE COUNTRY AND PLACE OF USAGE.
- BEFORE PERFORMING ANY CONNECTION MAKE SURE THAT MAINS POWER IS OFF.
- INSTALL THE MAINS POWER LINE SEPARATELY FROM THE SIGNALS LINES.



WARNING

CONDENSATE INSIDE THE DEVICE

THE DEVICE COULD BE DAMAGED BY CONDENSATE IF THE GAP BETWEEN THE TRANSPORTATION OR STOCK TEMPERATURE AND THE INSTALLATION SITE IS HIGHER THAN 20 °C (68°F).

- BEFORE OPERATING THE DEVICE MAKE SURE THAT IT IS PLACED ON THE NEW OPERATION SITE FOR A FEW HOURS SO THAT IT CAN ADAPT TO THE NEW CONDITIONS.



WARNING

MISSING GROUND/PE CONNECTION

ELECTRIC SHOCK DANGER

DEPENDING ON THE MODEL OF THE DEVICE, CONNECT THE POWER SUPPLY AS FOLLOWS:

- POWER PLUG: MAKE SURE THAT THE PLUG HAS A CONNECTION FOR THE PE/GROUND CONDUCTOR. CHECK THAT THE CONNECTION FOR THE GROUND/PE CONDUCTOR AND THE POWER PLUG ARE COMPATIBLE.
- TERMINALS CONNECTION: CONNECT THE TERMINALS AS ILLUSTRATED IN THE WIRING DIAGRAM. CONNECT FIRST THE GROUND/PE CONDUCTOR.



WARNING

DANGEROUS CONTACT VOLTAGE

ELECTRIC SHOCKS MAY HAPPEN IF THE WIRING HAS NOT BEEN PERFORMED PROPERLY.

- FOR INFORMATION ABOUT THE WIRING TECHNICAL SPECIFICATIONS SEE THE CHAPTER "ELECTRICAL CONNECTIONS (PAGE 11)".
- ON THE INSTALLATION SITE OF THE DEVICE RESPECT THE DIRECTIVES AND LAWS IN FORCE ABOUT ELECTRICS SYSTEMS WITH NOMINAL VOLTAGES BELOW 1000 V.

2.2 Wiring the signal lines



WARNING

UNSUITABLE POWER VOLTAGE

THE POWER VOLTAGE AT 24 V/1A MUST BE A SAFETY LOW VOLTAGE AT LIMITED POWER WITH SAFE ELECTRICAL SEPARATION (SELV).
CONNECT THE SIGNAL LINES ONLY TO DEVICES THAT ARE FEATURED WITH A SAFE ELECTRICAL SEPARATION ON THEIR POWER SUPPLY.

- The connection lines to the relays outputs, to the binary inputs and to the analog outputs must be shielded.
- Connect the signal lines to D-sub connectors on the back of the instrument.
- In order to suppress the formation of sparks through the relay contacts (e.g. limiter relay) some RC elements are to be connected as shown on the figure below. About this topic, it is a good rule to remember that an RC element delays the switch off of an inductive component (e.g. A solenoid valve). So the element C should be calculated on the basis of the following empiric rule:
 - $R = RL/2$; $C = 4L/R^2L$.
 - Normally these values are sufficient $R = 100 \Omega$ and $C = 200 \text{ nF}$.
 - For the RC element it is recommended to use a non-polarized capacitor.
- When operating with DC it is also possible to install a spark extinguishing diode instead of the RC element.

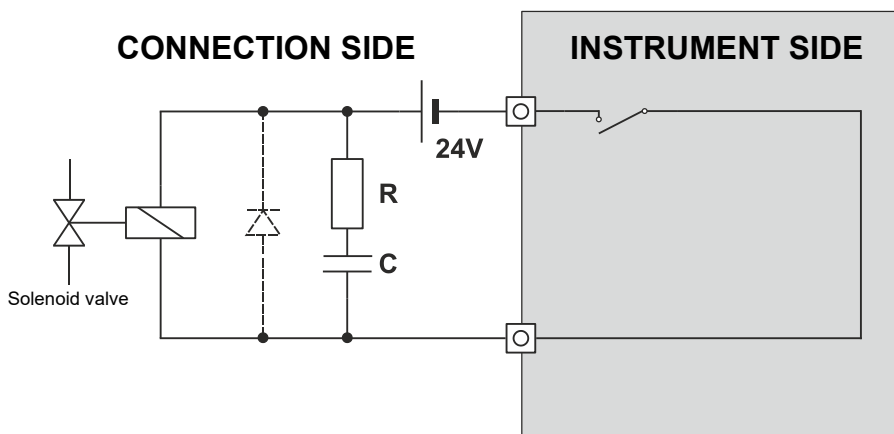

Figure: Sparks suppression on a relay contact

- Analog outputs

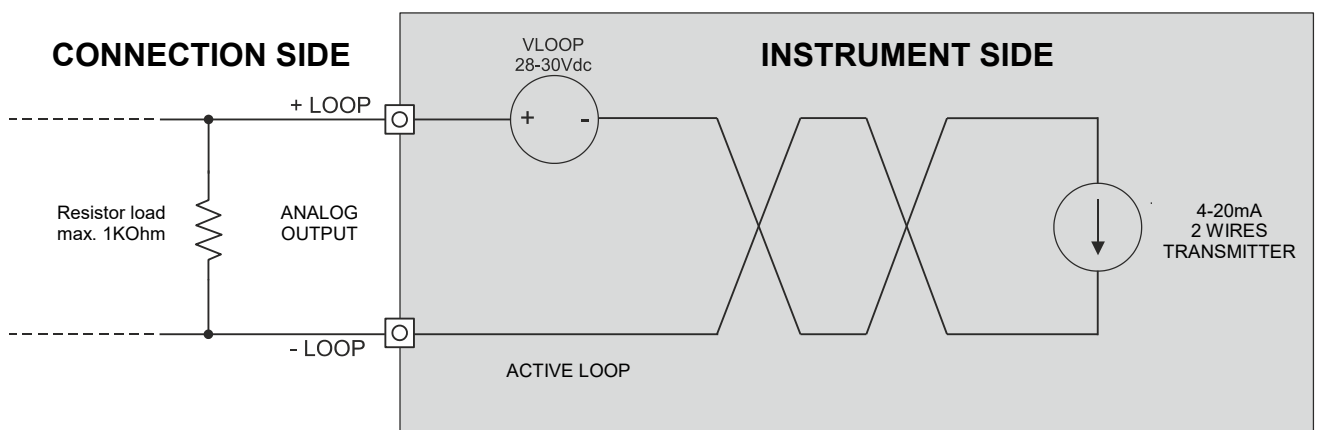

Figure: Connection of the load resistance to the analog output.

2.3 Connection of the serial port RS485 half duplex according to MODBUS® RTU protocol

The **S9000-RACK** features a serial output RS485 half duplex, which can be used to connect the instrument to a PC, through the communication protocol MODBUS® RTU.

The MODBUS® registry table is available at www.seitronamericas.com.

Connection diagram:

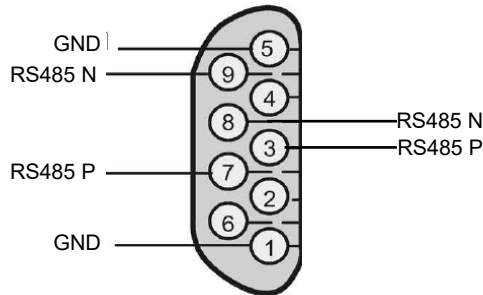

WARNING

- THE RS485 NETWORK SUPPORTS UP TO 32 CONNECTED DEVICES.
- IF THERE ARE MORE INSTRUMENTS CONNECTED TO THE SAME RS485 NETWORK, IT IS ADVISED TO SET THE SAME COMMUNICATION SPEED.

Bus wiring example:

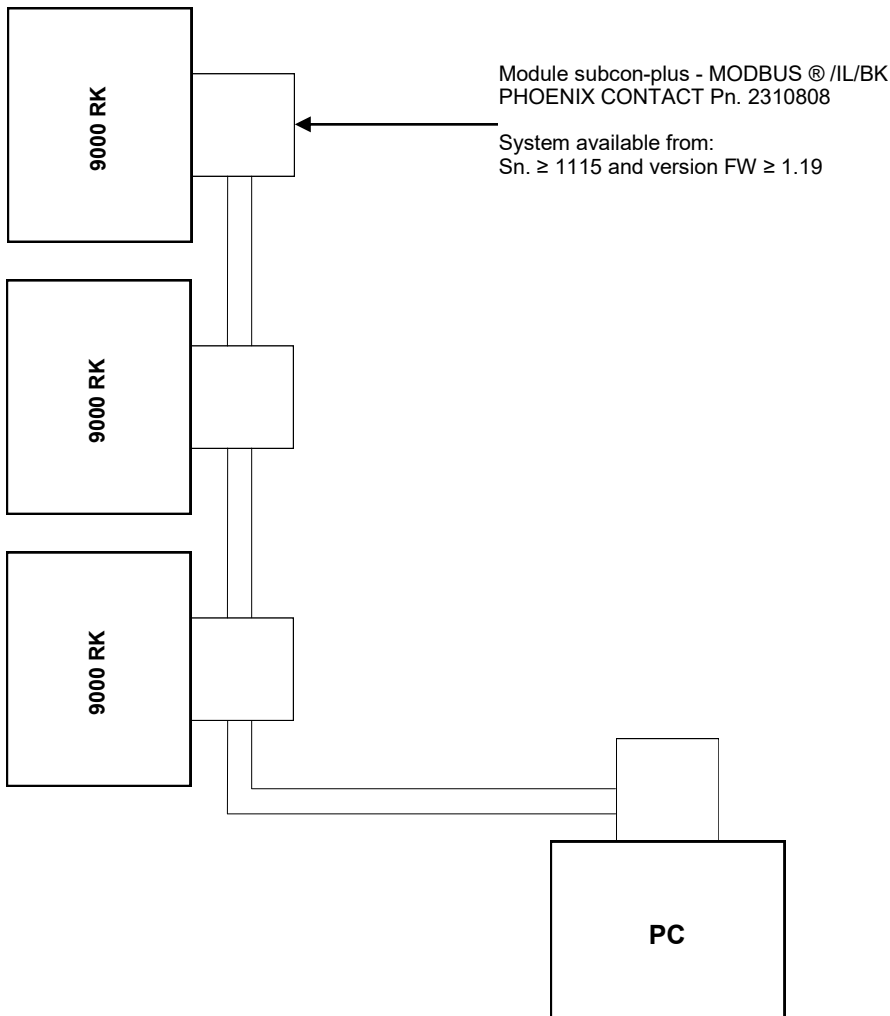

2.4 Analog outputs through 37 poles connector (8 outputs 4..20mA and 1 relay output)

The **S9000-RACK** features:

- Eight 4..20mA outputs, to which it is possible to associate, via the parameter "4..20mA configuration," one of the measurements that the instrument can make, in order to translate a measurement into a current value available at the output.
- A relay output, with voltage-free changeover contacts:
 - Relay output 4 associated with the alarm, upon activation from the appropriate parameter "Alarms."

Standby Contact:

When the standby contact is activated via software, the analyzer displays the standby message, with the gas pump off, the keypad disabled, and the standby pop-up present.

Then, when the standby contact is deactivated, the instrument resumes normal operation, with the gas pump on, the keypad working, and the standby pop-up absent.

When the instrument resumes operation, it performs a cleaning cycle followed by an autozero cycle, with suction from the "Zero Cal" nozzle.

If the instrument is started with the standby contact active, the standby pop-up is immediately present and the instrument does not perform autozero.

Wiring diagram:

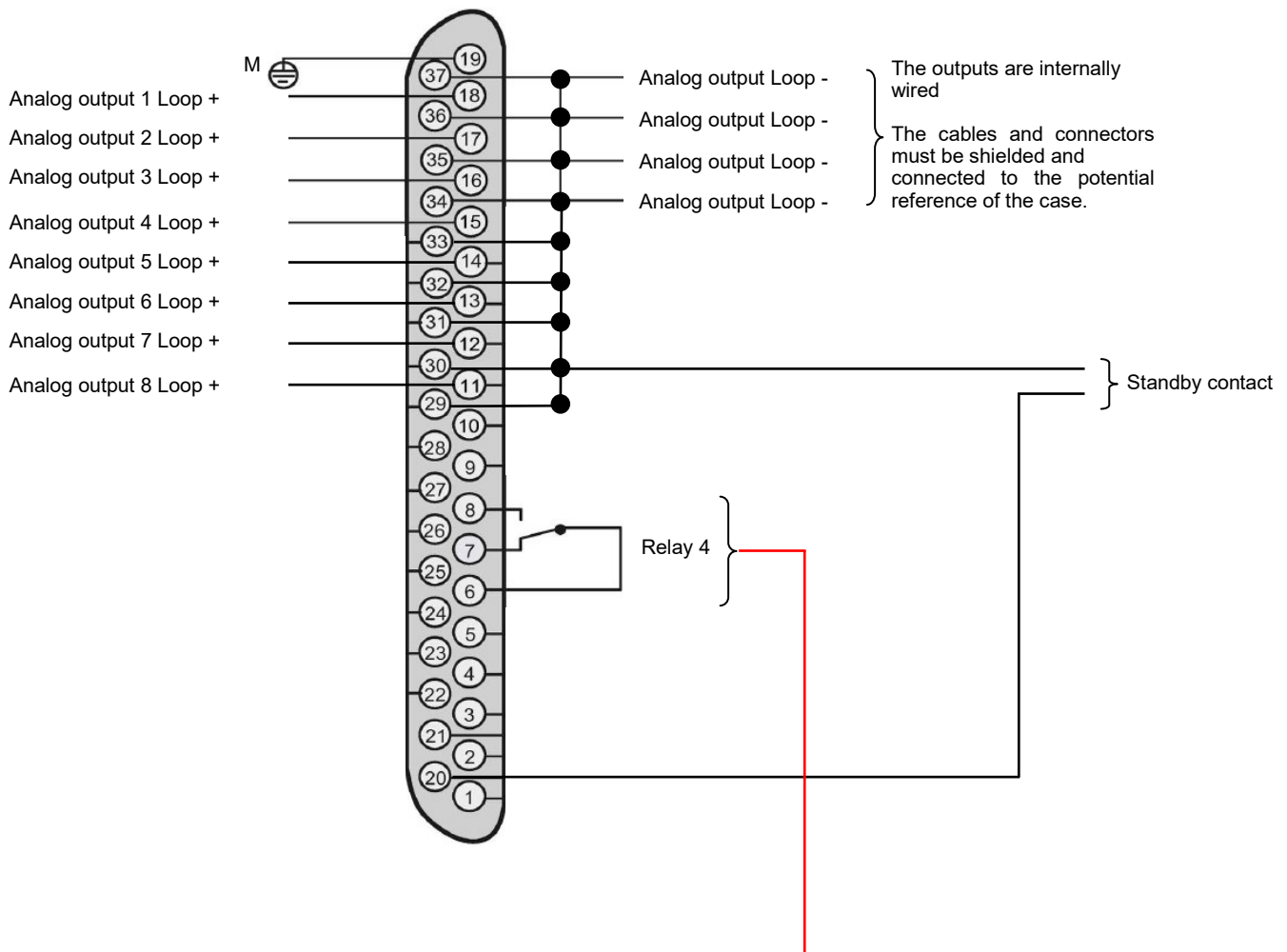

WARNING

RELAY 4 CANNOT BE USED TO CONNECT AN ALARM. ITS FUNCTION IS PURELY TO SWITCH THE GAS LINE FROM L1 TO L2. THE INSTRUMENT STARTS WITH THE LINE SET TO L1.

CAUTION.

If the current signal measured by the instrument is floating (or has unstable behavior), the ground reference between the measure device and the instrument must be equipotential by shorting pins 28 and 1 of the 37-pin connector.

This operation is not always necessary.

It becomes essential only when S9000-RACK is connected via the 4 ... 20 mA output to an UNISOLATED PC or PLC. Lack of isolation of the latter, in fact, causes instability of the current signal and consequently incorrect measurement.

Short circuit diagram:

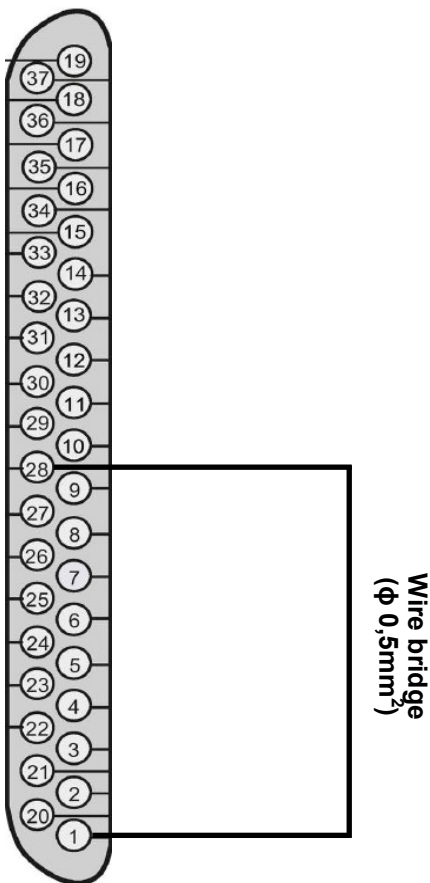

3.1 Connection to PC via supplied USB cable

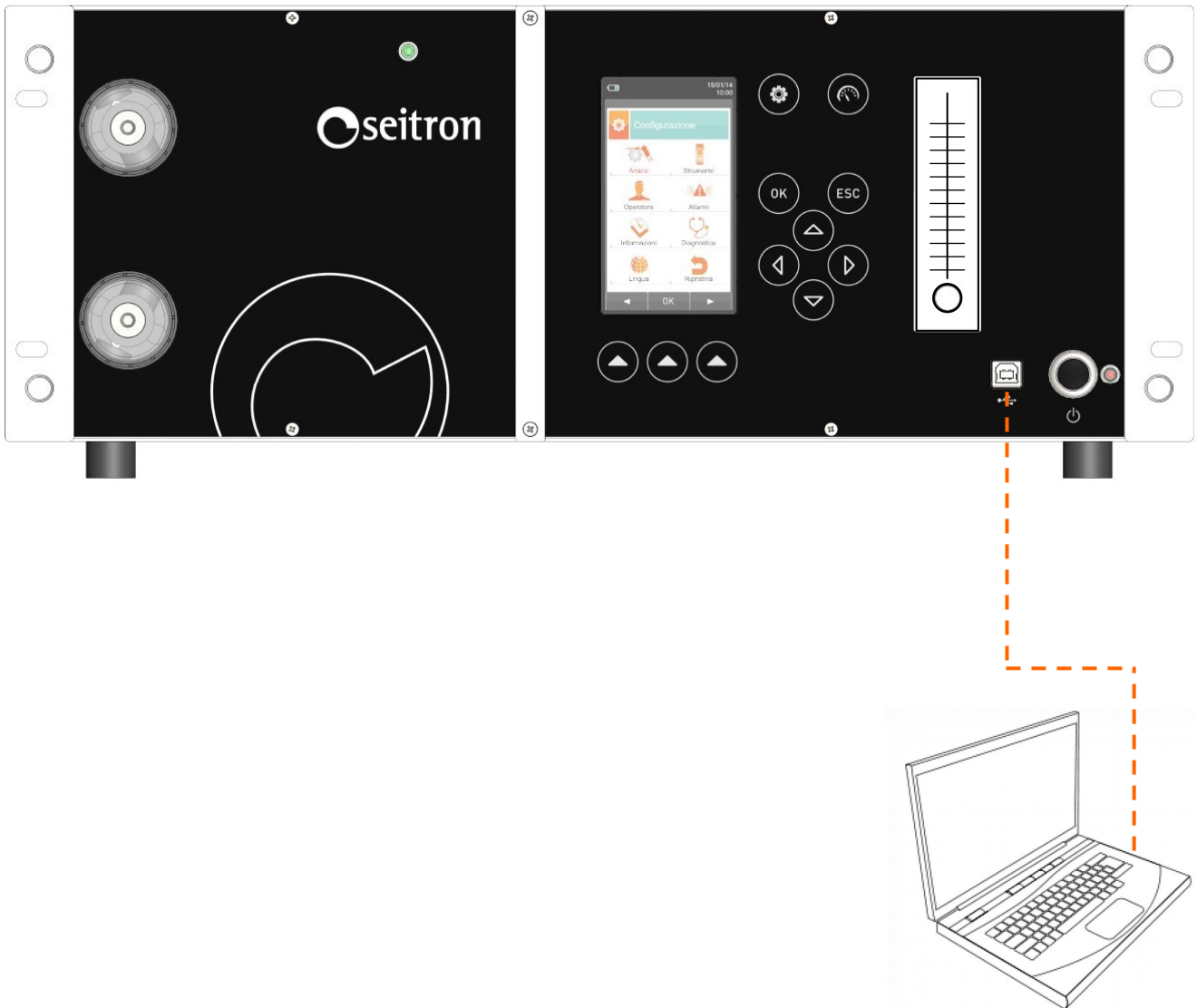

3.2 Connection to PC via Ethernet cable

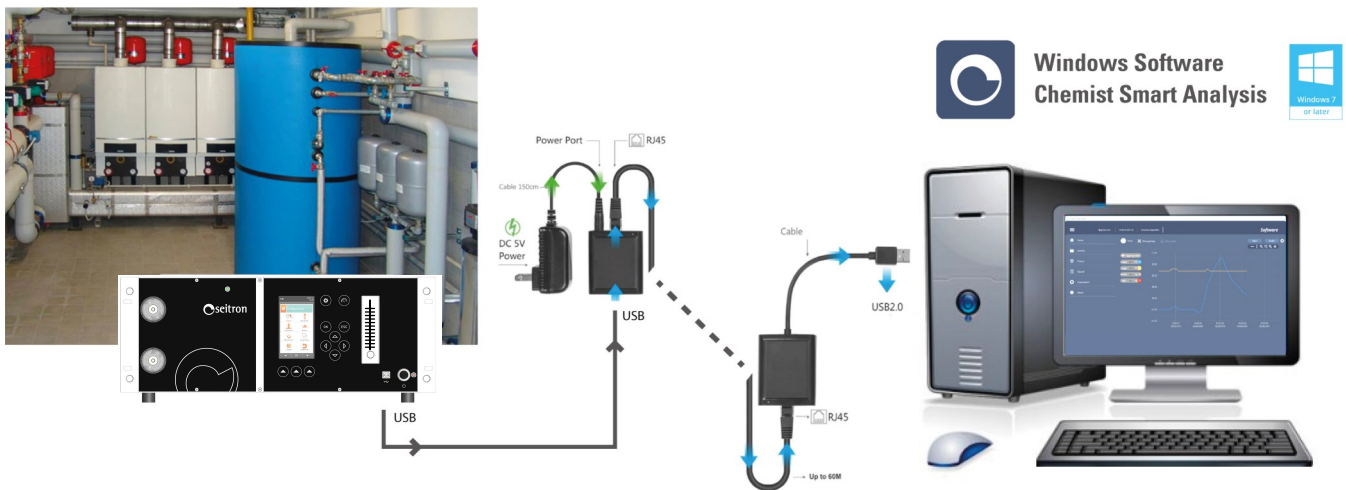

ATTENTION

- IN ORDER TO SAVE, STORE ANALYSIS DATA AND MANAGE THE COMBUSTION ANALYSIS MAIN PARAMETERS CONFIGURATION, CAN ONLY HAPPEN VIA THE PC, HAVING PREVIOUSLY INSTALLED THE "SEITRON SMART ANALYSIS" SOFTWARE PROVIDED WITH THE INSTRUMENT.
- IN ORDER TO CONNECT THE S9000-RACK TO THE ETHERNET IT IS NECESSARY TO PROPERLY CONNECT TWO USB => ETHERNET CONVERTERS.
- ONE OF THE TWO CONVERTERS MUST BE POWERED BY AN EXTERNAL SUPPLY SOURCE, BECAUSE S9000-RACK DOES NOT PROVIDE POWER TO THE USB PORT.



ATTENTION

- IT IS RECOMMENDED TO SUSPEND THE AUTOMATIC WINDOWS UPDATES AND THE STAND BY STATE OF THE PC, BECAUSE IN CASE OF ACTIVATION OF EITHER OR BOTH PROCESSES, THE COMMUNICATION WITH THE SOFTWARE "SEITRON SMART ANALYSIS" IS SUSPENDED.

3.3 Wiring diagram - Back Panel

3.3.1 Remote air intake filter assembly

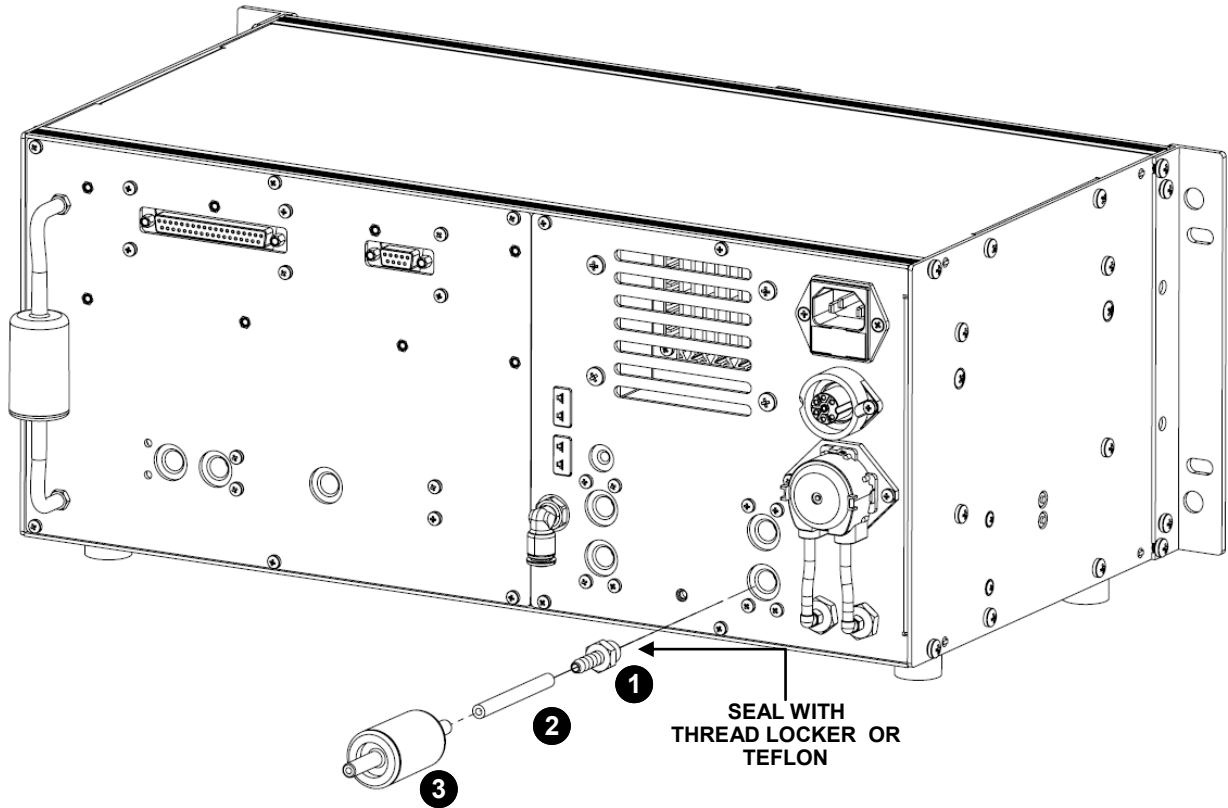

WARNING

- USING THE DUST FILTER ASSEMBLY IS COMPULSORY TO GRANT THE CORRECT OPERATION OF THE INSTRUMENT.

3.3.2 Junctions assembly - optional

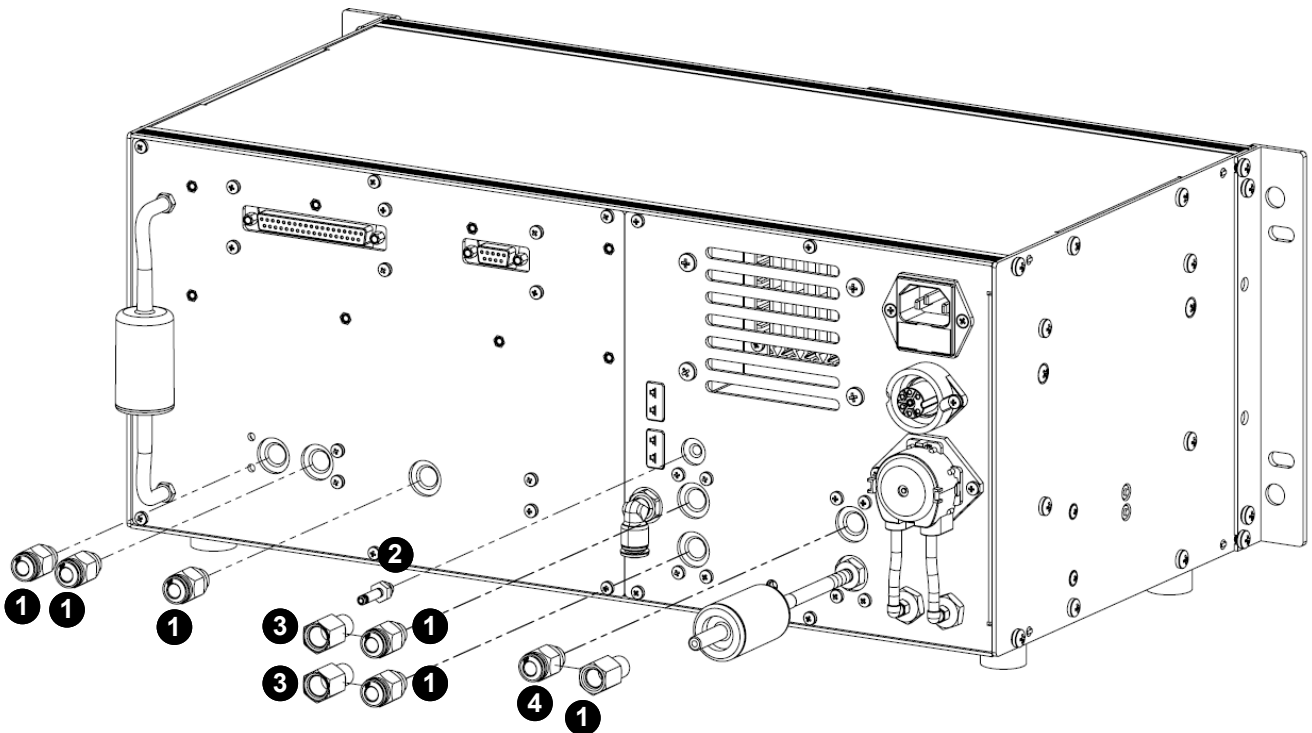

- ❶ Male junction 1/8" GAS BSPP → hose coupling Ø external 6 mm (0.2 inches) (6 pieces provided)
- ❷ Male junction M5 → hose coupling Ø external 4 mm (0.15 inches) (1 piece provided)
- ❸ Male junction 1/8" GAS BSPP → female Ø 9 mm (0.35 inches) (1 piece provided)
- ❹ Male junction 1/8" GAS BSPP → female Ø 8 mm (0.3 inches) (1 piece provided)



WARNING

- WHILE MOUNTING THE JUNCTIONS ON THE INSTRUMENT, SEAL THEM WITH THREAD LOCKER OR TEFLON.

3.3.3 Wiring diagram - Back cover

37 poles connector (8 4..20mA outputs and 1 relay output)
 Make available for the user 8 4..20mA outputs and 1 relay output with voltage free changeover contacts.

Power supply
 100 .. 240V~, 50 .. 60Hz
 With cable and IEC C14 plug.

Serial connector RS485
 Serial communication port type RS485 half duplex according to MODBUS[®] RTU protocol

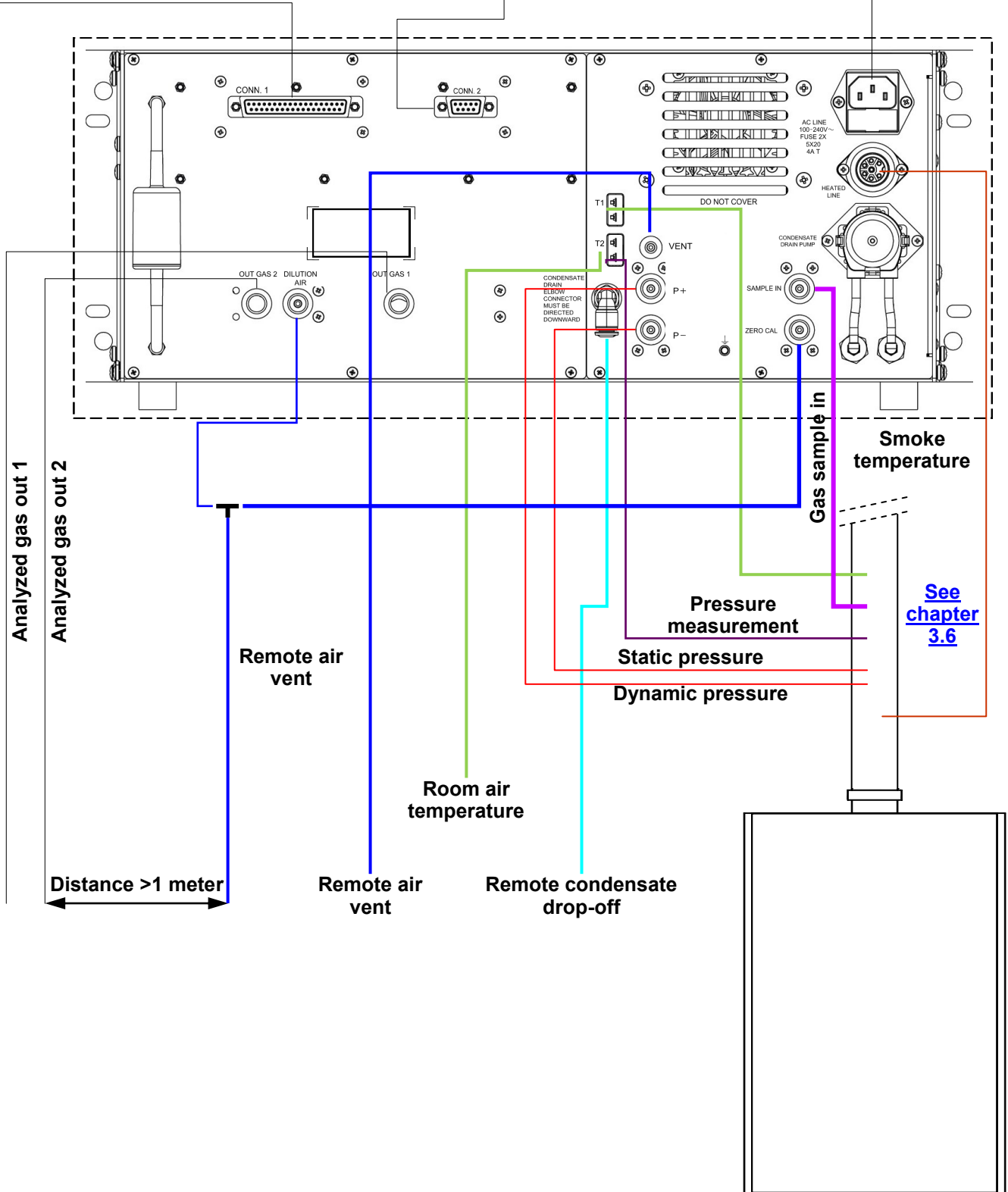

3.3.4 Connection to the nitrogen/synthetic air cylinder.

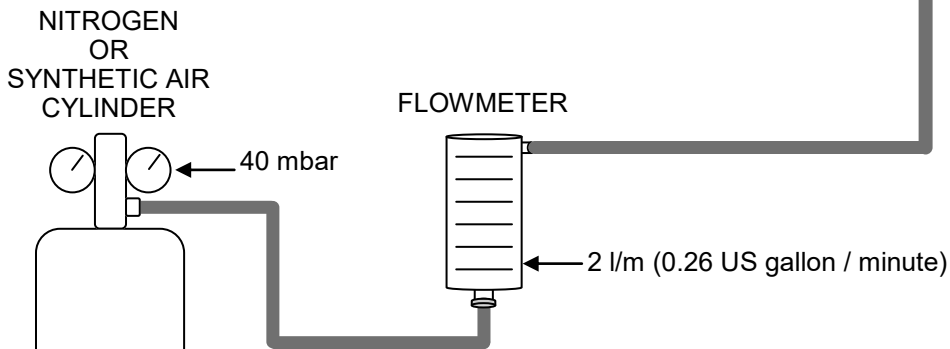
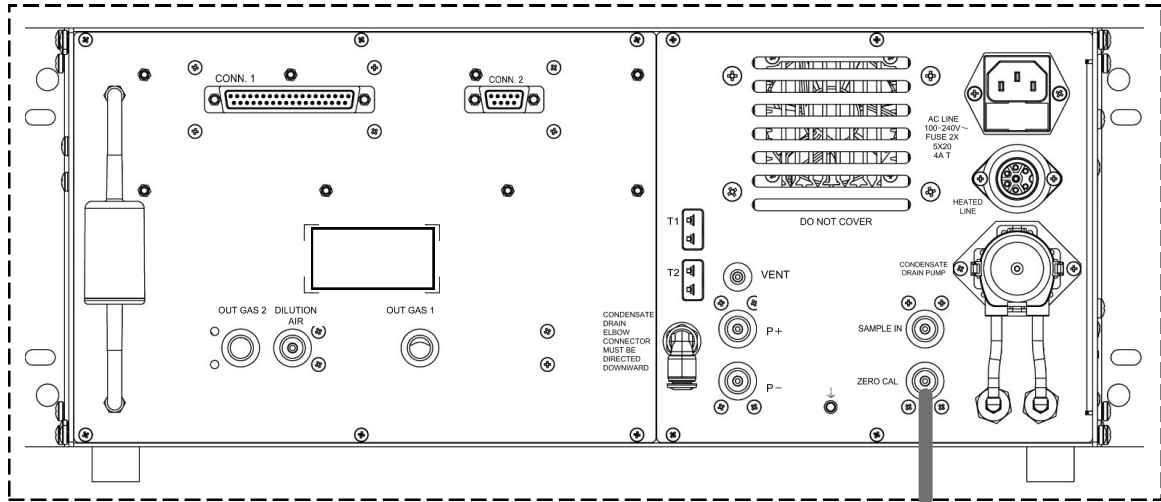

OPTIONAL CONNECTOR ASSEMBLY (INCLUDED)

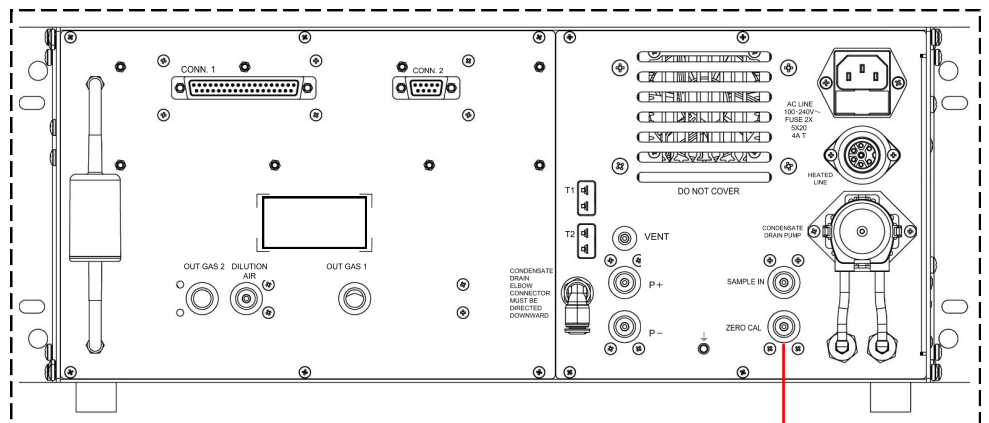

SEAL WITH
THREADLOCKER OR
TEFLON

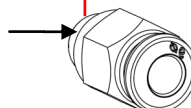

MALE 1/8 GAS BSPP → MALE \varnothing 6mm (0.2 inches)



3.3.5 Pitot Tube and Flue Gas Sampling Probe Connection

In order to perform combustion analysis and at the same time carry out flue gas velocity measurement, it is necessary to connect the flue gas sampling probe and Pitot tube to the instrument at the same time.

Mounting pneumatic adapters to the instrument

If a Pitot tube and a flue gas sampling probe equipped with quick couplings are used, the three adapters supplied with the instrument must be mounted on the instrument, as indicated in [Section 3.3.2 Fitting Fittings - Optional](#).

- Pneumatic adapters:
- Female 1/8 GAS BSPP => \varnothing 8mm (0.3 in) => to connector "SAMPLE IN"
 - Female 1/8 GAS BSPP => \varnothing 9mm (0.35 in) => to connector "P+"
 - Female 1/8 GAS BSPP => \varnothing 9mm (0.35 in) => to connector "P-"

Connecting the pitot tube to the instrument

- Connect the Pitot tube (optional) to the inputs P+ and P- which are normally used for measuring the differential pressure:

- Static Pressure Line: P-
- Dynamic Pressure Line: P+

Connecting the flue gas sampling probe to the instrument

- Connect the cable related to the Tc-K thermocouple of the flue gas sampling probe to the T1 connector of the instrument.
- Connect the fitting related to the flue gas sampling line (8 mm diameter connector) to the "SAMPLE IN" connector of the instrument.
- Insert on the fitting related to the line for pressure measurement (diameter 9 mm), the cap **AATB010001SE** supplied with the pitot tube.

CAUTION.

To make this connection, in case of using the third-party Pitot tube, it is necessary to purchase the cap **AATB010001SE**.

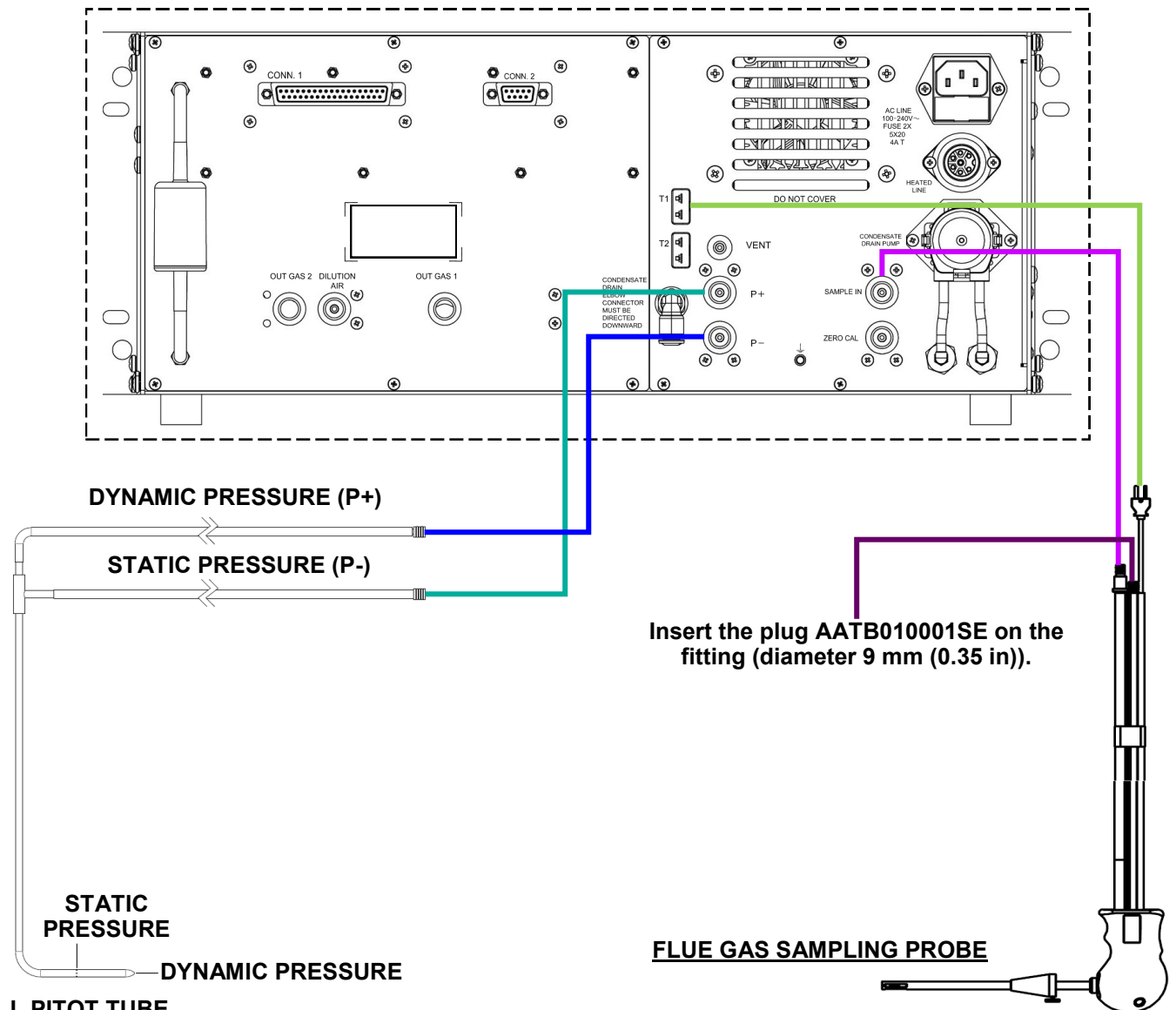



3.4 Pitot tube

By using a Pitot tube and a thermocouple type Tc-K, the instrument can also measure gas flow velocity (air/smoke).

Connecting the Pitot tube to the instrument

- Connect the Pitot tube (optional) to the inputs P+ and P- which are normally used for measuring the differential pressure.
- Connect the cable related to the thermocouple Tc-K of the smoke temperature probe to the instrument T1 connector.

WARNING

- If the Pitot tube is used along with the Tc-k thermocouple, connect the related connector to input T1 of the instrument. In this case the smoke temperature probe must **NOT** be connected.
- In order to connect the two pipes it is necessary to perform the following modification:
 1. Mount on the instrument the two provided junctions with 1/8 M thread for quick connection of the tube \varnothing external 6 mm (0.2 in) (to be sealed with thread locker or Teflon).
 2. Cut two 10 cm (0.4 in) pieces of polyurethane tube \varnothing 6mm (0.2 in) (provided) and connect one piece in each junction.

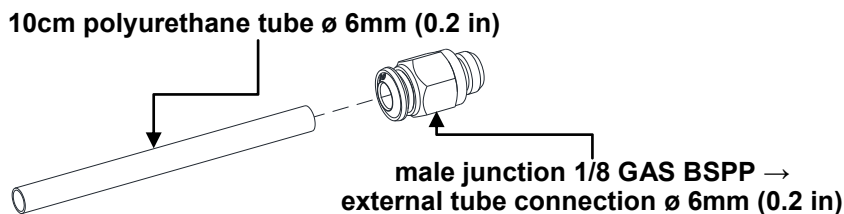

3. Remove the quick connection junctions from the Pitot tube.
4. Insert on the free end of the polyurethane tube the related pipes of the Pitot tube.

Alternatively, two male adapters must be mounted on the instrument with 1/8 GAS BSPP thread → FEMALE \varnothing 9mm (0.35 in) to be sealed with thread locker or Teflon.

S PITOT TUBE

S PITOT TUBE

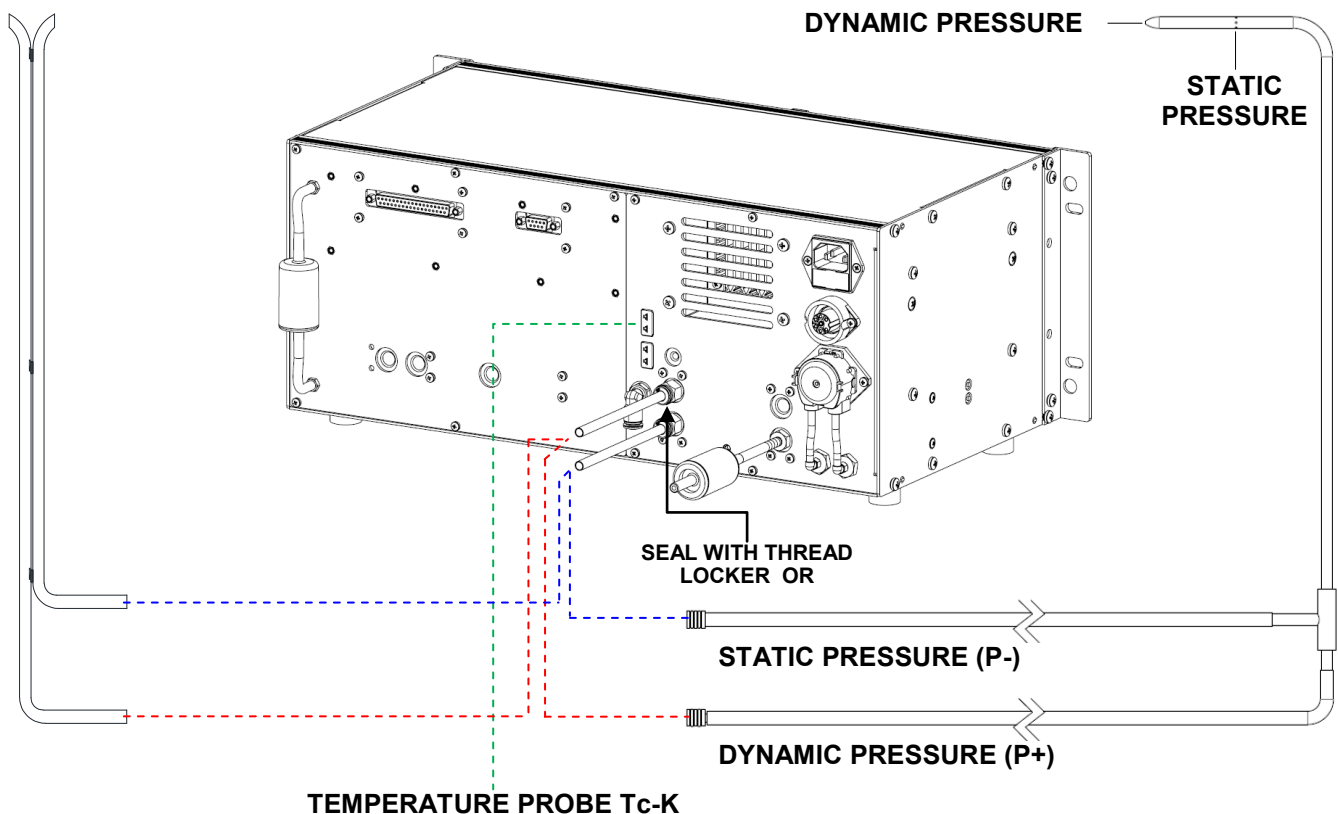

In order to perform the test see [chapter Measurements](#).



3.5 Features of the smoke suction line

General description

The thermocouple type K (Ni-NiCr) provides stable temperature measurements at high temperature. The instrument is internally equipped with a Pt100 thermistor, allowing to measure the internal temperature; this sensor is also used to measure the temperature of the room where the instrument is placed. If it is needed to detect the temperature of the combustion air directly from inside the suction duct, the optional remote Tc-K sensor must be used. It is suggested to make this measure to calculate the system efficiency if the combustion air temperature is different from the room temperature where the instrument is placed. Two pneumatic connectors are provided with the instrument to allow the connection of the smoke probes (featured with fast connector) to the instrument.

Technical features

Temperature sensor:	Thermocouple type K (Ni-NiCr) - IEC584 - class 1
Pneumatic connector:	Male 1/8 GAS BSPP
Temperature Sensor connector:	TC-K mignon
Pneumatic connectors:	Female 1/8 GAS BSPP => ø 8mm (0.3 in) Female 1/8 GAS BSPP => ø 9mm (0.35 in)

Connection

As shown in chapter 3.3.3, the gas sensor probe has to be connected to the instrument as follows:

- ◆ Male connector Tc-K: connect on input **T1**.
- ◆ Pneumatic male connector: connect to the instrument input marked with "**SAMPLE IN**".
- ◆ Pneumatic male connector: connect to the instrument input marked with "**P-**".

WARNING: If a smoke probe equipped with fast connectors is being used, it is necessary to plug in the two provided connectors on the instrument, as shown on the image below.

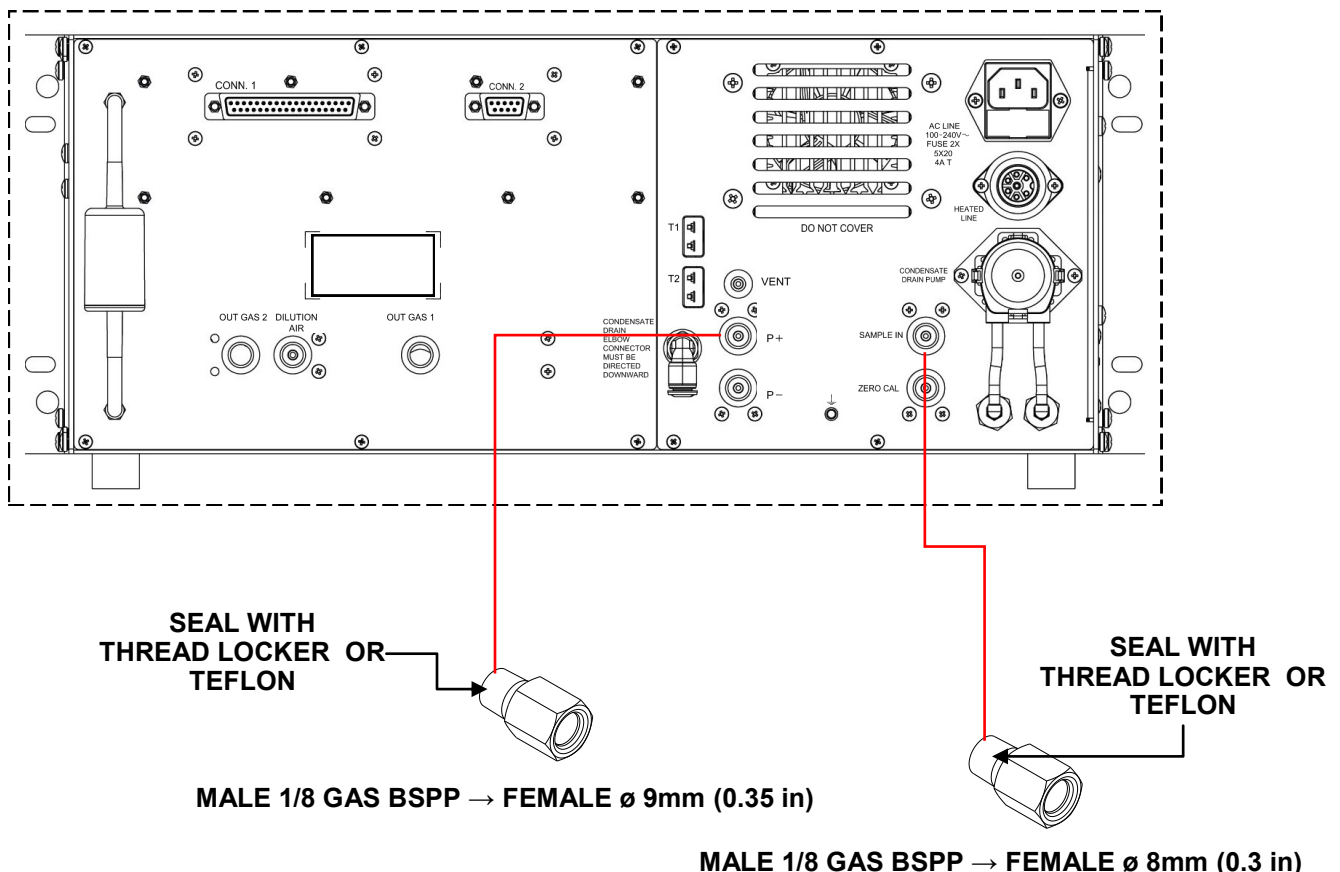

3.6 Features of the heated smoke suction line (for the measurement of NOx - SOx)

The heated line is used for application where it is needed to perform the measure of NOx/SOx for long time intervals. An heated line maintains the gas temperature above the dew point until the gas gets to the internal cooler. The Peltier cell conditioning unit dries up the sample avoiding the dilution of NO2 and SO2 in the condensation water.

The heated gas sampling line (temperature > 90 °C or 194 °F) allows to sample the gases to be analyzed and carry them into the analyzer without condensation occurring on the way in order to avoid that gases like NOx and SOx dissolve in the condensate water making them not measurable by the sensors in the measuring chamber.

The gas, kept warm by the heated line, flows in the instrument passing through an efficient Peltier module cooler which reduces very quickly the gas temperature down to 5 °C or 41 °F.

This quick thermal shock creates an immediate condensation of the water in a dedicated tank; the gas, now dried, is therefore carried to the measuring chamber.

The condensation water resulting from the combustion process is then expelled from the instrument through a membrane pump for liquids.

Heated line technical features:

Heated hose:

Material:	Internal measurement hose: Teflon External insulation: water-repellent Megamide
Length:	3 m (10 ft)
Bending radius:	140 mm (5.5 in)
Power per meter:	65 Watts
Power supply:	From the instrument with special R24 connector, 110Vac - 230Vac automatic voltage switching
Temperature control:	NTC 10K
Temperature set-point:	Settable from 90°C to 130°C or 194 °F to 266 °F
HEATED LINE connector:	Female connector compatible with the following male connectors: BINDER 692- 6P+T pn 9902170007 AMPHENOL 6P+T pn C016-30H06-100-12

WARNING

For higher loads it is necessary to use the command of the tube to power a relay or a power SCR, by using the terminals 1 and 3 of the connector to command the relay or the SCR. The command has a voltage of 110 V.

To the "HEATED LINE" connector, it is possible to attach an electrically heated hose.

Follow the diagram below:

Follow the diagram below:

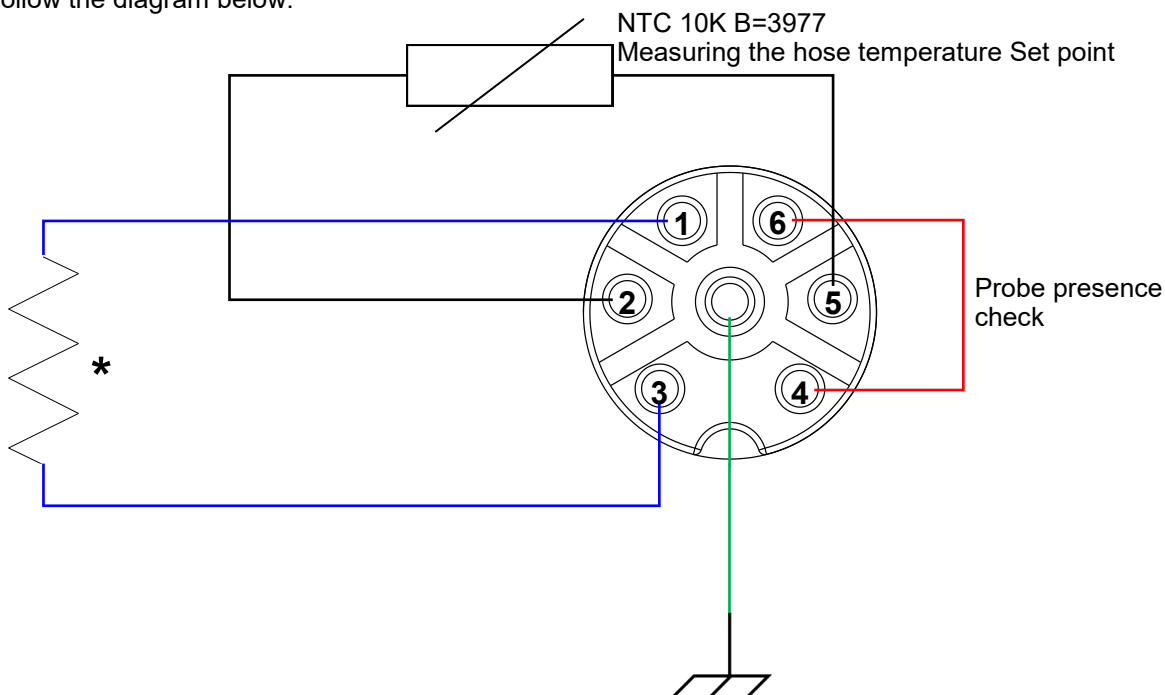

*: Heater 110V 195W for 3 meters (10 ft) of hose (65W / m).
It is possible to power up to 500W corresponding to 8 meters of hose.

3.7 Combustion air temperature probe

This probe is used to measure the combustion air temperature, if the pick up point of the latter is in a different area in relation to where the instrument is installed.

Technical features

Temperature sensor: Sensor element: Thermocouple type K (Ni-NiCr) - IEC584 - class 1

Connector: TC-K mignon

Working range: -20.0°C .. +1250.0°C or -4 °F .. +2282 °F

If the probe is not connected to the instrument, the considered combustion air temperature is the temperature detected by the instrument internal sensor, so the temperature is the one of the room in which the instrument is installed.

Connection:

As shown in [chapter 3.3.3](#), the probe has to be connected to the instrument as follows:

- ♦ The polarized male connector of the thermocouple has to be connected to the **T2** input. The improper insertion of the same is not possible thanks to the different length of the tips.

3.8 Draft measurement

The draft measurement has to be performed using the negative pressure input P-.

If the value of the measurement is negative, it means that the smoke outlet has a negative pressure, while on the contrary if the value is positive the smoke outlet has a positive pressure.

3.9 Remote air suction spots

Use the inputs 'DILUTION AIR' and/or 'ZERO CAL' to move the pick up point for the clean air, in an area free from pollute gases or from the outlet of the instrument itself.

Connection

- ♦ The connectors to be used are: Male 1/8 GAS BSPP

4.1 Technical features

Power supply:	100 .. 240V~, 50 .. 60Hz With power cable with IEC C14 socket.
Power absorption at 230V:	100 VA
Fuses:	2 x 4A Delayed. Size: 5x20mm. (0.20 inches by 0.8 inches).
Display:	TFT 4.3", 272 x 480 pixels graphic color with backlight.
Connectivity: Communication port:	USB connector TYPE B CONN. 1: RS485 (half duplex) with communication protocol MODBUS® RTU D-sub 9 poles female. CONN. 2: 8 outputs 4..20mA (active loop) + 1 relay output D-sub 34 poles female.
Power LOOP 4-20ma:	28-30 Vdc max resistance load 1 KOhm
Relay outputs:	1 x 1A 24V AC/DC SPDT Voltage free contacts.
Contact input Dilution	Closed contact input Enable stand by. Contact input open Instrument in operation.
Autozero: Dilution:	Automatic autozero cycle with the probe inserted in the chimney. Widens the CO sensor measurement range up to 100,000ppm (10.00%). Programmable as simple protection of the CO sensor with the intervention level set by the user.
Gas measurement sensors:	Up to 5 configurable sensors: electrochemical, NDIR (single cell) and pellistor.
Infrared bench:	NDIR bench - Up to 3 configurable gases: CO, CO2, CH4 Measurements in the IR bench can be linearized in air, in nitrogen, or non-linearized*.
Programmed fuels:	15 factory pre-set plus 32 user-programmable.
Self-diagnosis:	Checks all functions and internal sensors and reports any abnormal operation.
Temperature measurement: Room temperature measurement:	Double input for thermocouple K with mini connector (ASTM E 1684-96). Using the internal sensor or TCK sensor connected to input T2.
Line filter:	Replaceable cartridge, 95% efficiency with 20um particles.
Suction pump:	2,2 l/min head at the stack up to 300 hPa or 0.6 gallons per minute (gpm) / 11.1 inches of water column (inH2O).
Flow measurement:	Internal sensor.
Flowmeter:	Flow rate: 0.4 .. 5 LPM (liters of air per minute). Accuracy: ±5% Full scale

Cooler

Drying system:	Quick moisture condensation with cyclone
Type:	Peltier module
Cooler set-point temperature:	+5° C or 41 °F
Max temp. deviation from the set-point:	+10° C or 50 °F
Condensate drainage:	With diaphragm pump 150ml/min or 0.04 gallons per minute (gpm)
Duty cycle diaphragm pump:	30s on - 30s off
Warm up time:	~ 15 .. 20 minutes
Working temperature:	-5°C to +45°C or 23°F to 113°F in Fahrenheit

Draft test:	With the piezoelectric sensor, the draft can be measured continuously because the system can also perform the self-zeroing of the sensor through an internal valve.
-------------	---

Operation temperature:	-5°C .. +45°C or 23°F to 113°F
Storage temperature:	-20°C .. +50°C or -4°F to 122°F
Humidity limit:	20% .. 80% RH
Protection grade:	IP21

Weight:	~ 7 Kg or 15 pounds
---------	----------------------------

Compliant with European Standards EN 50270, EN 50379-1 and 50379-2:
See the declaration of conformity

Compliant with USA standard CTM030 and CTM034.

*Valid only for NDIR bench AACSE38.

5.1 General overview of the Analyzer

The S9000-RACK is an industrial tool for measuring polluting gases.

The instrument was configured and calibrated before delivery. Through the menus of the instrument, many parameters can be adjusted retrospectively based on specific application needs.

In this operation and maintenance manual, all information for the use and maintenance of the instrument is provided.

Operations are described based on the maximum configuration of the analyzer. Should the instrument be equipped differently (e.g., absence of components such as cooler, peristaltic pump, fume suction pump, external IR and frontal anti-dust filters, etc.), the information in this manual should be applied according to the context. **All parts that may not be present in the configuration of the purchased instrument will be marked with the symbol *.**

The numerical values used are for illustrative purposes only. Therefore they may differ from the values actually displayed on the instrument.

The instrument is featured with:

- Rack mounting 19" with 4 HE for the mounting of adjustable frames, racks with or without telescopic guides. Alternatively, the instrument features four rubber feet on the lower surface, so that it can stand horizontally on a flat surface.
- Pneumatic circuit which can accommodate up to 5 sensors of the FLEX-sensors series.
- Housing for fitting an NDIR (infrared) bench. Depending on the instrument configuration, it is able to measure one or more of the following gases: CO - CO₂ - CH₄.
- Female pneumatic connectors with 1/8 GAS BSPP thread.
- The gas autozero cycle can be performed with the probe inserted in the stack.
- The autozero of the pressure sensor (piezoresistive, temperature compensated) can also be performed with the gas probe inserted in the stack.
- 1 alarm with visual and acoustic signal is programmable for one measurement parameter (user chosen).
- Intuitive user interface: the instrument can be used without the support of the user manual.
- Wide (55x95 mm) and bright TFT color display which delivers great readability thanks to the zoom function and an efficient backlight.
- Serial communication port type RS485 according to protocol MODBUS[®] RTU in order to connect to the PC for the analysis reading.
- USB communication port type A, for PC communication with the dedicated software provided with the instrument, to archive the analysis and the configuration of the main parameters for the combustion analysis. The S9000-RACK allows to memorize and archive the analysis data exclusively from remote, using a PC with the software **Chemist Smart Analysis** previously installed.
- 4 .. 20 mA isolated output (8 configurable channels - Active loop)
- One SPDT alarm relay output, AC/DC 24V 1A.
- One input contact

Main functions:

- Gas analysis:
 - Comes with 15 most common fuel parameters (such as natural gas, LPG, gas oil and fuel oil).
 - Possibility to store in memory the parameters for 32 further fuels, once their chemical composition is known.
- Monitoring of pollutants (combustion)
- Calculating Total Carbon (%).

Measurable gases:

- O₂
- CO/H₂
- CO
- NO
- NO₂
- SO₂
- H₂S
- NH₃
- H₂
- CO₂
- CH₄

Measurements:

- Draft in the stack
- Combustion air temperature
- Smoke temperature
- Air speed for air or flue gas leaving the stack with the use of Pitot tube

Maintenance:

- The sensors can be replaced by the user without sending back the instrument to the technical assistance center for the sensors are provided pre-calibrated, while the NDIR bench can't be replaced directly by the user, but only in an authorized Seitron assistance center.
- To get an accurate measure, the instruments needs an annual calibration, which can be performed on the field through the procedure "Calibration On Site" and the use of gas mixtures special samples.

Certificate of calibration

The instruments comes with an ISO 9001 calibration certificate.

5.2 Working principle

The gas sample is taken in through the gas probe, by a diaphragm suction pump inside the instrument and it is cleaned of humidity and impurities by the Cooler and the filter located inside the instrument. The sample is then analyzed in its components by electrochemical and infrared sensors. The electrochemical sensor guarantees high precision in a time interval of about 60 minutes during which the instrument can be considered very stable. When measurement is going to take a long time, we suggest auto-zeroing the instrument again after flushing the inside of the pneumatic circuit for three minutes with clean air. During the zero calibrating phase, the instrument aspirates clean air from the environment and detects the cells' drifts from zero (20.95% for the O₂ cell), then compares them with the programmed values and compensates them. The pressure sensor autozero must, in all cases, be done manually prior to measuring pressure. The values measured and calculated by the microprocessor are viewed on the LCD display which is backlit to ensure easy reading even when lighting is poor.

5.3 CO dilution*

One of the characteristics of the electrochemical sensor for the measurement of CO is the need to require very long self-calibration time in case it has been in contact with high gas concentration (greater than the full scale) for a long time.

The CO sensor is therefore protected in this instrument by an automatic dilution system that allows to extend the measuring range of the sensor without overloading the sensor itself.

The dilution system allows to have the CO sensor efficient any time and ready to perform properly even in case of very high concentration of CO.

The dilution system also allows to extend the measurement range of the CO sensor as follows:

- up to 100,000 ppm for a CO sensor with 8000 ppm full scale
- up to 250,000 ppm for a CO sensor with 20,000 ppm full scale

In this way in addition to better manage the wearing of the sensor, it is also possible to continue sampling, without any work interruption.

CAUTION: CO dilution is only possible if the sensor is installed in position S2. In case the CO sensor is installed in a position other than S2, this function is not available.

5.4 Fuel types

The device is provided with the technical data of the most common types of fuels stored in its memory. By using the PC configuration program, available as an optional, it is possible to add fuels and their coefficients in order to define up to a maximum of 32 fuels, other than the default ones. For more details see Annex A.

5.5 Peltier module condensation assembly (Cooler)*

The gas sample needs to be suitably dehumidified and purified of solid combustion residues before being analyzed ("dry analysis").

For this purpose, the **S9000-RACK** is equipped with a Peltier condensation assembly; this has the goal of quickly cooling the gas sample down to a temperature of 5° C (41 °F).

The cooler causes the moisture contained in the gas to condensate thus allowing the gas to reach the sensors without undergoing significant changes in its composition.

This system is particularly useful when water-soluble components have to be analyzed (eg. SO₂, NO₂, etc.).

In order to raise the efficiency of the Peltier module condensation assembly, it is advisable to use, for the sampling of gas, a special probe with heated head and/or heated hose.

This probe includes in its interior a thermo-resistance for the automatic control of the temperature, which must be maintained above the dew point, always above 90°C to prevent unwanted condensation at the probe level. The heated hose allows the gas to reach the Peltier module condensation assembly unchanged in its chemical characteristics.

In conditions of extreme ambient temperature (+45° C, 113 °F) it is possible that the internal temperature of the cooler is not maintained at +5° C but tends to move up to +10° C /+15° C or +50 °F / +59 °F, this temperature is still sufficient to obtain the drying of the gas, with a loss of efficiency up to 10% of drying.

5.6 Remote condensate sink

On the back of the instrument is located the output of the condensation water.

By properly connecting an appropriate silicone hose it is possible to move the output point of the condensation water.

5.7 External dust filters*

Two dust filters protect the pneumatic circuit and the gas sensors.

These two filters are in series with each other: the first is the lowest one, the second is at the top.

Consisting of a cylinder in transparent polycarbonate, these are located on the left side of the analyzer.

A replaceable, low-porosity filter is positioned within each cylinder with the purpose of retaining solid particles suspended in the flue gas. The filter has an efficiency of 95% for 20um solid particles.

It is recommended to replace the filters any time they are significantly dirty (see section '**MAINTENANCE**').

5.8 Dust filter for the NDIR bench protection*

For further protection of the NDIR bench, an additional dust filter has been inserted into the analyzer, replaceable by the user.

Placed on the back of the instrument, it consists of a cylinder in transparent polycarbonate with a filter inside, having an efficiency of 99% with 20um solid particles, with the purpose of retaining solid particles suspended in the flue gas.

We recommend to check the filter once a year during periodic maintenance.

5.9 Remote air intake

On the back of the analyzer there is a pneumatic connector '**ZERO CAL**'. This connector is the air intake used to perform the auto-zero for the gas sensors.

To this connector, it is necessary to joint the special anti-dust filter, provided with the instrument (for the assembly diagram, see chapter 3.3.1 Wiring diagram - Back panel - Remote air intake filter assembly).

On special conditions, if the instrument is placed in a closed and polluted environment, it is possible to move the instrument air intake in a lean air environment, using a small tube to be put after the anti-dust filter.

5.10 Remote air intake connected in Nitrogen or Synthetic air

Connecting the '**ZERO CAL**' pneumatic connector (1/8 GAS BSPP female connection) to the Nitrogen cylinder or the Synthetic Air cylinder (with 20.95% oxygen concentration) allows the instrument to perform autozero in the absence of CO₂, which is normally present in ambient air albeit in low concentrations. It is not possible to perform the autozero in Nitrogen in case an oxygen sensor is installed on the instrument, as it requires 20.95% oxygen to perform the autozero.

The gas must be applied to the instrument ensuring an inlet flow of 2l/min (0.5 gpm) or a pressure of 40mbar. The male 1/8" BSPP gas fitting, supplied, can be fitted to this connector for connection to the cylinder (for fitting, see Chapter 3.3.3 Connection Diagram - Connection to Nitrogen/Synthetic Oxygen Cylinder).

5.11 Pressure sensor, piezoelectric, temperature compensated

The instrument is equipped with a piezoresistive differential pressure sensor, temperature compensated, for measuring pressure or draft.

This sensor is differential type thus, thanks to the second measurement port, can be used for measuring the draft (negative pressure) in the stack, for differential pressure measurement, for measuring the velocity of the flue gas using a Pitot tube, for flow measurement.

The measurement range is -1,000 Pa .. +20,000 Pa.

Any potential drift of the sensor are nulled thanks to the autozeroing system which in this instrument can be operated with the flue gas probe inserted in the chimney, because the instrument is equipped with a solenoid valve that switches the pressure measurement to the ambient, thus allowing to zero the sensor in air.



WARNING
ANY PRESSURE APPLIED TO THE SENSOR GREATER THAN ± 300 hPa MAY CAUSE A PERMANENT DEFORMATION OF THE MEMBRANE, THUS DAMAGING THE SENSOR IRREVERSIBLY.

5.12 Smoke suction pump*

This diaphragm pump, located inside the instrument, is operated with a DC engine powered by the instrument in order to obtain the optimal suction flow rate of the flue gas for the ongoing analysis; an internal sensor measuring the flow allows to:

- Maintain a constant flow rate of the pump
- Check the state of efficiency of the pump
- Check the level of filter clogging

5.13 Condensate sink pump*

The membrane pump has the purpose to automatically empty the condensation water, and it is controlled directly by the microprocessor with alternating turning on/off.

The time interval between one turn on/turn off cannot be modified by the user and it is set to 30 seconds.

When the system is functioning correctly it is monitored by an internal pressure sensor which measures these time intervals. In case of anomalies, an error message will appear on the display.

5.14 Draft measurement with sensor automatic autozero

The S9000-RACK performs the draft pressure measurement

The auto-calibration of the sensor is carried out through the switching of an internal valve that allows to perform the zeroing procedure without removing the probe from the stack.

This feature is particularly useful when the analysis is taken in 'data logger' mode.

5.15 Temperature measurements

The **S9000-RACK** performs temperature measurements using Tc-K probes, to be connected to input T1 or T2 placed on the back of the instrument.

5.16 Calculating total carbon

The tool is able to calculate, through an algorithm, the total carbon present in the atmospheres of steelmaking furnaces. This comes in particularly useful due to the fact that varying the amount of carbon (carbon content) in steel changes its mechanical properties (e.g., impact resistance, deformability, etc.); thus, thanks to this calculation, one is able to control the presence of carbon (%C) in production processes.

5.17 Autozero difference in air, nitrogen and synthetic air

The instrument autozero can be performed in Nitrogen or in air, and the difference is as follows:

- With autozero in nitrogen and synthetic air, absolute CO₂ concentration is measured.
- With autozero in air, the CO₂ concentration relative to ambient CO₂ is measured.

5.18 Available software

Seitron Smart Analysis

PC software, downloadable from the web site www.seitronamericas.com, with the following features:

- Displays the plate data of the instrument.
- Sets the instrument parameters.
- Sets the emission analysis mode.
- Starts the analysis and remotely shows the data coming from the instrument.
- Stores the data in .csv files.

5.19 External size

Size: RACK 19" height 4U

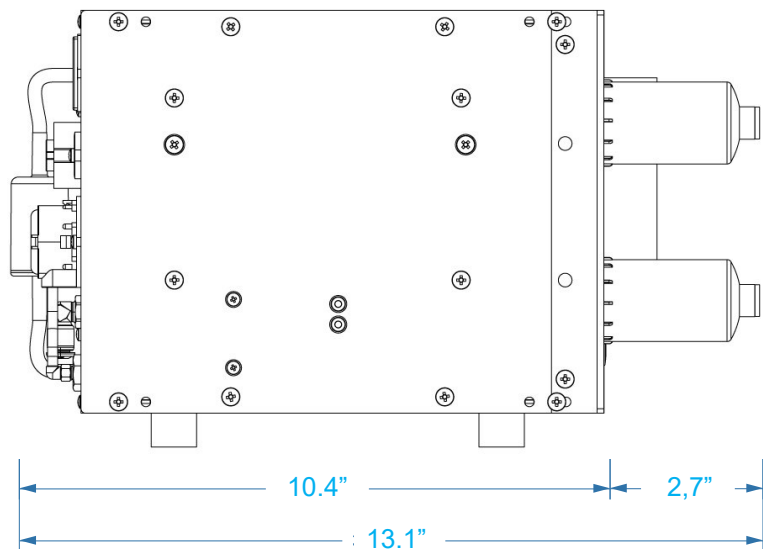
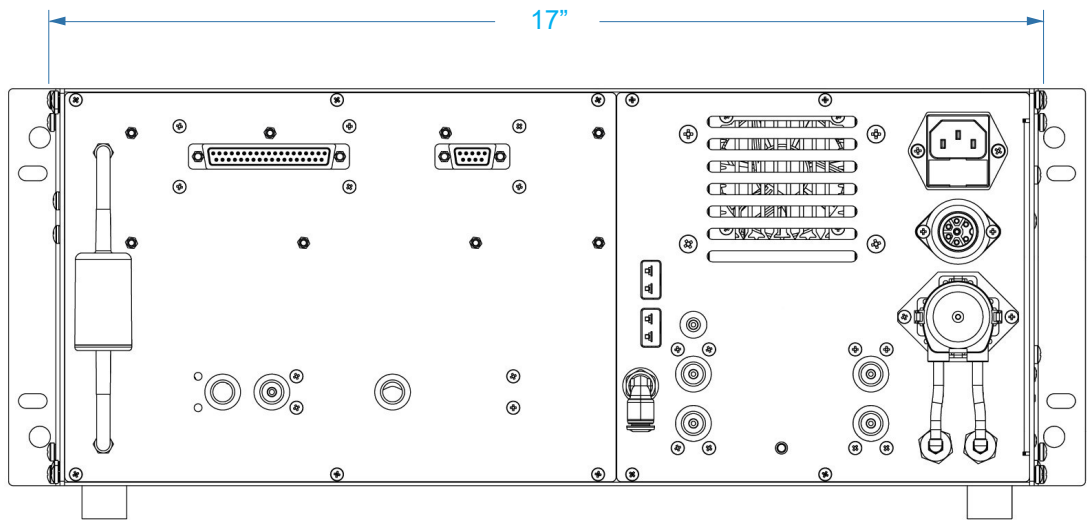
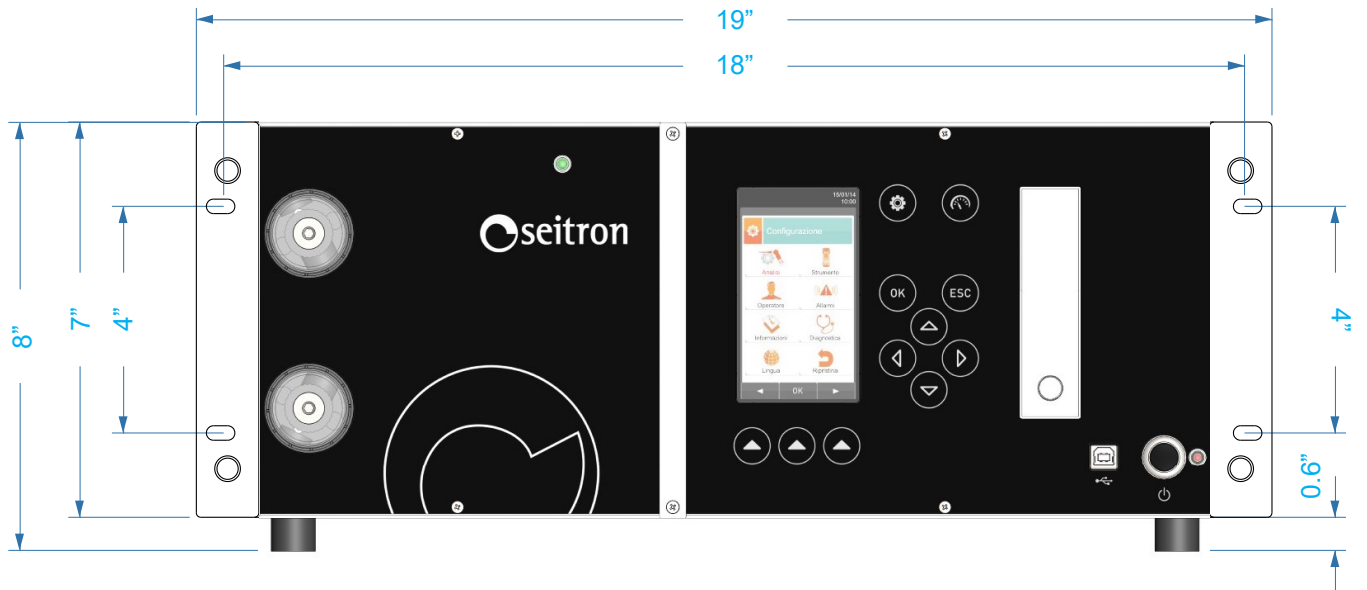

5.20 Measurement and Accuracy Ranges

MEASUREMENT	SENSOR	RANGE	RESOLUTION	ACCURACY	Response time (t90)	
O ₂	Electrochemical sensor	0 .. 100.0% vol	0.01% vol	±0.3% vol. ±1% measured value	0 .. 30.00% vol 30.01% .. 100.00% vol	20 s
O ₂	Electrochemical sensor	0 .. 25.0% vol	0.1% vol	±0.2% vol		20 s
CO with H ₂ compensation	Electrochemical sensor	0 .. 8000 ppm	1 ppm	±10 ppm ±5% measured value ±10% measured value	0 .. 200 ppm 201 .. 2000 ppm 2001 .. 8000 ppm	50 s
diluted	Electrochemical sensor	10.00% vol	0.01% vol	±20% measured value		
CO Low range with H ₂ compensation	Electrochemical sensor	0 .. 1000.0 ppm	0.1 ppm	±2 ppm ±5% measured value	0 .. 40.0 ppm 40.1 .. 1000.0 ppm	50 s
diluted	Electrochemical sensor	100000 ppm	10 ppm	±20% measured value		
CO *3	Electrochemical sensor	0 .. 8000 ppm	0,1 ppm (0..1000ppm) 1 ppm (1001..8000ppm)	±2 ppm ±5% measured value ±10% measured value	0 .. 40.0 ppm 40.1 .. 500.0 ppm 501.0 .. 8000.0 ppm	50 s
diluted *3	Electrochemical sensor	100000 ppm	10 ppm	±20% measured value		
CO Mid range	Electrochemical sensor	0 .. 20000 ppm	1 ppm	±100 ppm ±5% measured value ±10% measured value	0 .. 2000 ppm 2001 .. 4000 ppm 4001 .. 20000 ppm	50 s
diluted	Electrochemical sensor	25.00% vol	0.01% vol	±20% measured value		
CO Hi range	Electrochemical sensor	0 .. 10.00% vol	0.01% vol	±0.02% vol or ±5% m.v. ±5% measured value	0 .. 2.00 % 2.01 .. 10.00 %	50 s
NO	Electrochemical sensor	0 .. 5000 ppm	1 ppm	±5 ppm ±5% measured value	0 .. 100 ppm 101 .. 5000 ppm	40 s
NO Low range	Electrochemical sensor	0 .. 500 ppm	0.1 ppm	±2 ppm ±5% measured value	0 .. 40.0 ppm 40.1 .. 500.0 ppm	40 s
NOx	Calculated					
SO ₂	Electrochemical sensor	0 .. 5000 ppm	1 ppm	±5 ppm ±5% measured value	0 .. 100 ppm 101 .. 5000 ppm	50 s
SO ₂ (J57-2017)	Electrochemical sensor	0 .. 1000 ppm	0,1 ppm	±2 ppm	0 .. 40 ppm	50 s
			1 ppm	±5% measured value	41 .. 1000 ppm	50 s
SO ₂ Low range	Electrochemical sensor	0 .. 500 ppm	0.1 ppm	±2 ppm ±5% measured value	0 .. 40.0 ppm 40.1 .. 500.0 ppm	50 s
NO ₂	Electrochemical sensor	0 .. 1000 ppm	1 ppm	±5 ppm ±5% measured value	0 .. 100 ppm 101 .. 1000 ppm	50 s
NO ₂ Low range	Electrochemical sensor	0 .. 500 ppm	0.1 ppm	±2 ppm ±5% measured value	0 .. 40.0 ppm 40.1 .. 500.0 ppm	50 s
CxHy	Pellistor sensor	0 .. 5.00% vol	0.01% vol	±0.25% vol		50 s
CO ₂	Calculated	0 .. 99.9% vol	0.1% vol			
CO ₂	NDIR sensor	0 .. 100.0% vol	0.1%	±1% vol ±2% vol ±5% vol	0.00 .. 10.00 % 10.01 .. 50.0 % 50.01 .. 100.0 %	50 s
H ₂ S Low range	Electrochemical sensor	0 .. 500 ppm	0.1 ppm	±5 ppm ±5% measured value	0 .. 100.0 ppm 100.1 .. 500.0 ppm	90 s
H ₂ S	Electrochemical sensor	0 .. 5000 ppm	0.1 ppm	±5 ppm ±5% measured value	0 .. 100.0 ppm 100.1 .. 500.0 ppm	40 s
			1 ppm	±10% measured value	501 .. 5000 ppm	
H ₂ *3,4	Electrochemical sensor	0 .. 2000 ppm	1 ppm	±10 ppm ±10% measured value	0 .. 100.0 ppm 100.1 .. 2000.0 ppm	90 s
H ₂ *4	Electrochemical sensor	0 .. 40000 ppm	10 ppm	±100 ppm ±10% measured value	0 .. 1000 ppm 1001 .. 40000 ppm	90 s
NH ₃	Electrochemical sensor	0 .. 500 ppm	0.1 ppm	±10 ppm ±10% measured value	0 .. 100.0 ppm 100.1 .. 500.0 ppm	90 s

MEASUREMENT	SENSOR	RANGE	RESOLUTION	ACCURACY	Response time (t90)	
CO	Bench NDIR AACSE38	500000 ppm (0 .. 50.0% vol)	1 ppm	±50 ppm	0 .. 2500 ppm	5 s
			10 ppm	±3% measured value	2501 .. 100000 ppm	
			10 ppm	±5% measured value	100001 .. 500000 ppm	
CO ₂		0 .. 50.0% vol	0.1% vol	±0.3% vol ±5% measured value ±10% measured value	0.00 .. 8.00 % 8.01 .. 40.00 % 40.01 .. 50.00 %	5 s
CH ₄		0 .. 1000000 ppm (100% vol.)	1 ppm	±50 ppm ±2% measured value ±3% measured value	0 .. 200 ppm 201 .. 50000 ppm 50001 .. 1000000 ppm	5 s
CO ₂		0 .. 50.0% vol	0.1% vol	±0.3% vol ±5% measured value ±10% measured value	0.00 .. 8.00 % 8.01 .. 40.00 % 40.01 .. 50.00 %	5 s
CO	Bench NDIR AACSE76	500000 ppm (0 .. 50.0% vol)	1 ppm	±50 ppm	0 .. 2500 ppm	5 s
			10 ppm	±3% measured value	2501 .. 100000 ppm	
			10 ppm	±5% measured value	100001 .. 500000 ppm	
HC		100000 ppm (0 .. 10.0% vol)	1 ppm	±10% measured value ±3% measured value ±5% measured value	0 .. 300 ppm 301 .. 4000 ppm 4001 .. 100000 ppm	5 s
CO ₂		Bench NDIR AACSE80**	0-25000 ppm	0.001% vol	0 .. 2500 ppm ±50 ppm 2501 .. 2500 ppm ±275 ppm	5 s
CO			0 .. 40% vol	0.001% vol	±0.5% FS o 0.2% vol	5 s
CH ₄	0 .. 10% vol		1 ppm	±1% FS o 0.1% vol	5 s	
Air temperature	TcK sensor	-20.0 .. 1250.0 °C	0.1 °C	±1 °C ±1% measured value	0 .. 100 °C 101 .. 1250 °C	
Flue gas temperature	TcK sensor	-20.0 .. 1250.0 °C	0.1 °C	±1 °C ±1% measured value	0 .. 100 °C 101 .. 1250 °C	
Pressure (draft and differential)	Piezoelectric sensor	-10.00 .. 200.00 hPa	0.01 hPa	±1% measured value ±0.02 hPa ±1% measured value	-10.00 .. -2.01 hPa -2.00 .. +2.00 hPa +2.01 .. +200.00 hPa	
Differential temperature	Calculated	0 .. 1250.0 °C	0.1 °C			
Air index	Calculated	0.00 .. 9.50	0.01			
Excess air	Calculated	0 .. 850 %	1 %			
Stack loss	Calculated	0.0 .. 100.0 %	0.1 %			
Efficiency	Calculated	0.0 .. 100.0 %	0.1 %			
Efficiency (condensing)	Calculated	0.0 .. 120.0 %	0.1 %			
PI ¹ (CO/CO ₂ ratio)	Calculated		0.01%			
C ² (% of measured carbon)	Calculated		0.01%			

** : Customized linear correction available upon request for accuracy ±0.15% Vol in the range 0-20%.

Note:



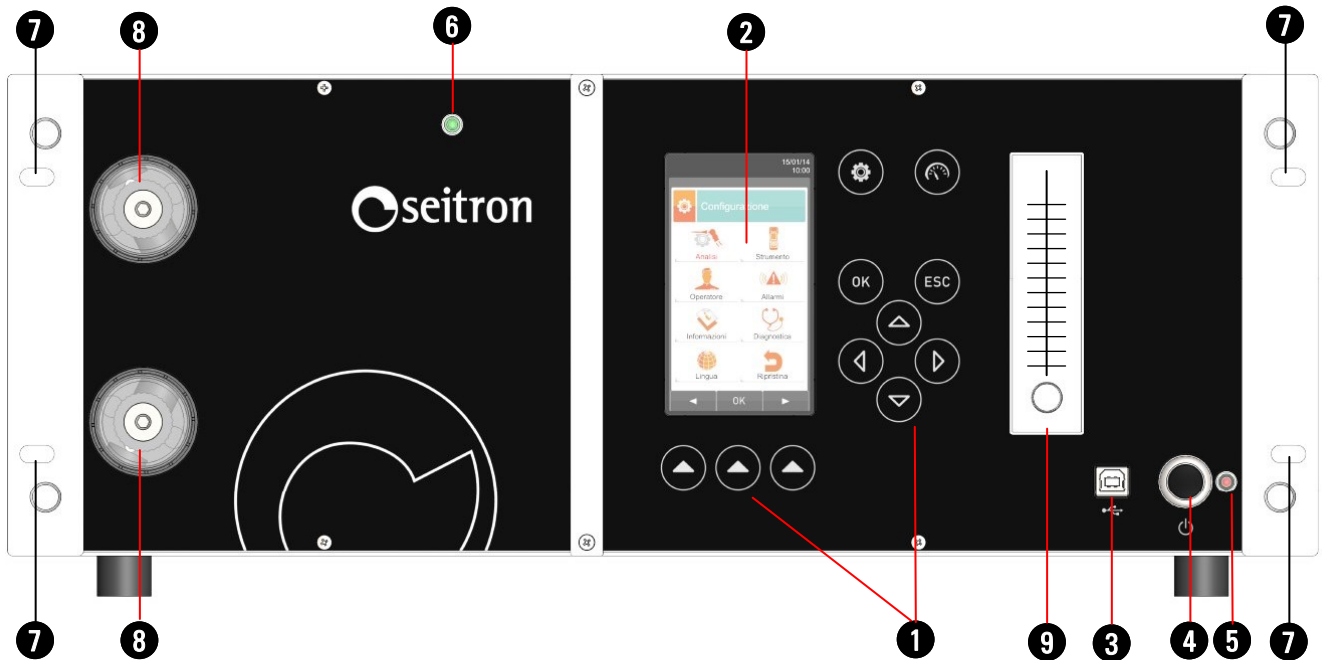

- 1: The Poison Index (P.I.) is a reliable indicator of the proper operation of the burner or boiler. Thus through a simple flue gas analysis, it is possible to determine whether maintenance work needs to be done.
- 2: The calculated carbon percentage is a measurement that the instrument obtains and displays by analyzing the fumes from steel production (in its various types). This comes in particularly useful because, as the amount of carbon in the steel varies, its properties change; therefore, by being able to display the measurement of how much carbon is present in the furnace (or converter), one is able to have precise control over the amount of the latter that must be present in the decarburization of the cast iron to obtain steel with the desired properties.
- 3: AACSE79 sensor-the intervention of dilution for CO measurement results in an increase in the measurement range to 100000 ppm, while H₂ measurement is decreased by a coefficient of 12.5.
- 4: If the AACSE79 sensor (H₂ 0 .. 2000 ppm) and the AACSE78 sensor (H₂ 0 .. 40000 ppm) are installed in the instrument at the same time, dilution will always be active with fixed threshold at 3000 ppm in order to protect the AACSE79 sensor (H₂ 0 .. 2000 ppm) from high H₂ concentrations measured by the AACSE78 sensor (> 3000 ppm).

6.1 Front cover



LEGEND:

1 Polycarbonate touch keypad and relevant main functions:

KEY	FUNCTION
	Activates the context keys shown on the display
	Access to the Configuration menu
	Access to the Measurements menu
	Confirm settings
	Quits the current screen

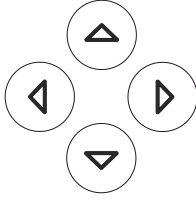
KEY	FUNCTION
	Select and/or Modify

2 Display

LCD 128 x 64 pixel backlit color display with 21 characters available and 8 lines. Allows the user to view the measured parameters in the most comfortable format; a Zoom function displays the measured values in magnified form.

WARNING: If the instrument is exposed to extremely high or extremely low temperatures, the quality of the display may be temporarily impaired. Display appearance may be improved by acting on the contrast key.

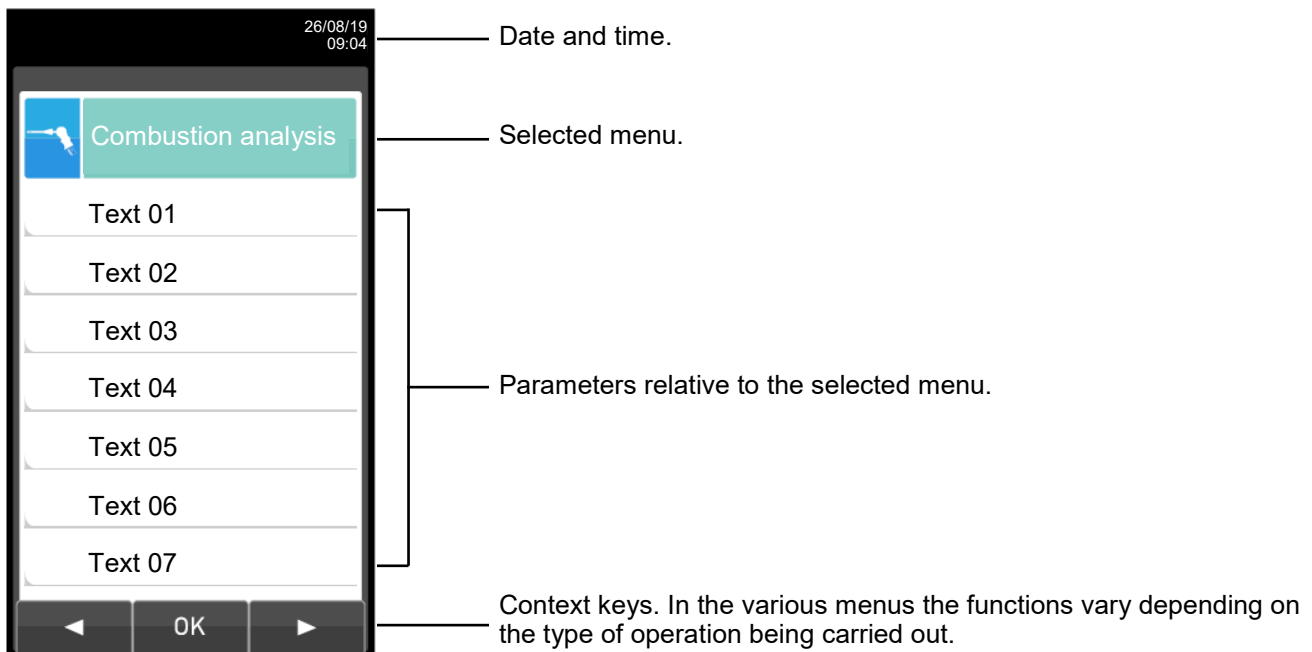

- 3 USB connector (type B)**
 Connector for connecting the instrument to a personal computer running Microsoft Windows 7 or higher, after installing the appropriate Seitron Smart Analysis software supplied with the instrument.
- 4 Power On/Off button**
 To turn on or off the analyzer hold this key down for a few seconds.
- 5 Programming LED**
 This LED provides important information during the firmware update procedure. For further details please refer to section [16.8 Firmware update](#).
- 6 Power Led**
 When this Led is on, it shows that the power is being delivered to the instrument.
- 7 Instruments fixing holes.**
- 8 External dust filters.***
- 9 External flowmeter.**
 The function of the external flowmeter is to measure and verify the flow rate value of the main pump, whether the instrument is in the process gas intake phase or in the autozero or sensor cleaning mode.

6.2 Back panel

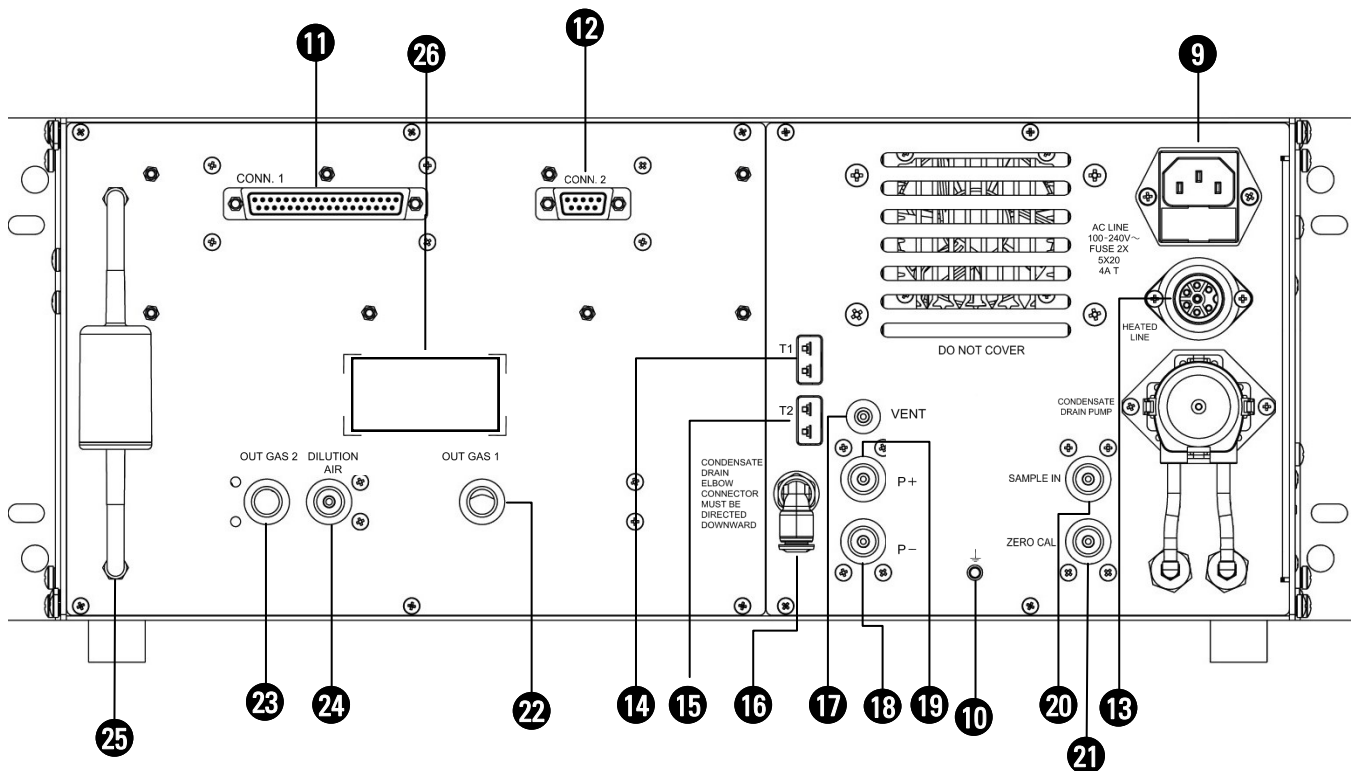

LEGEND:

- 9 Connector 'AC LINE - 100..240V~'**
Plug IEC C14 to connect the power cable to the instrument, provided with the instrument itself. On the plug there is a fuse-holder hidden under a flap, containing 2 fuses 5x20 4A T.
- 10 Connection for grounding of the instrument.**
- 11 37 poles connector (8 outputs 4..20mA, 1 relay output and 1 input contact)**
Makes 8 4..20mA outputs and 1 relay output with voltage-free changeover contacts available to the user.
- 12 Serial connector RS485**
Serial communication port type RS485 according to MODBUS[®] RTU protocol.
- 13 'HEATED LINE' Connector**
Plug for the heated line connection.
See chapter 3.6.
- 14 'T1' Connector**
Tc-K connector to plug in the male connector Tc-K of the probe for the measure of the smoke temperature.
- 15 'T2' Connector**
Tc-K connector to plug in the male connector Tc-K of the combustion air probe.
- 16 Condensation water drain**
- 17 'VENT' Connector - Female connector M5**
Air vent used by the pressure sensor to perform the self-zeroing. If the instrument is installed on a rack or in pressurized environments, the air vent must be moved remotely at room temperature.

18 Pneumatic connector 'P-' - female connection 1/8 GAS BSPP.
Negative input (P-) to be used for the draft measurement.

19 Pneumatic connector 'P+' - female connection 1/8 GAS BSPP.
Positive input (P+) to be used for the measurement of the pressure in general.



The inputs "P+" and "P-" are respectively the positive input and the negative input of the piezoresistive pressure sensor, with temperature compensation, so they are both used at the same time for the measurement of the differential pressure.

20 Pneumatic connector 'SAMPLE IN' - female connection 1/8 GAS BSPP.
Input for the connection of the gas sampling probe.

21 Pneumatic connector 'ZERO CAL' - female connection 1/8 GAS BSPP.
Inlet for connecting a remote air intake tube to perform autozero, in case the instrument is placed in a closed and polluted environment, the instrument air intake can be moved to a clean air environment using the 'ZERO CAL' connector.
In case the instrument is used for heat treatment, the 'ZERO CAL' connector should be connected to a Nitrogen or synthetic air bottle.

22 Connector 'OUT GAS 1' - female connection 1/8 GAS BSPP.
Analyzed gas remote output.

23 Connector 'OUT GAS 2' - female connection 1/8 GAS BSPP.
Analyzed gas remote output.

24 Connector 'DILUTION AIR' - female connection 1/8 GAS BSPP.
Remote air vent for CO dilution.



THE REMOTE AIR VENT FOR THE CO DILUTION MUST BE PLACED AT LEAST 1 METER AWAY FROM THE REMOTE ANALYZED GAS OUTPUTS.

25 Dust filter for NDIR (infrared) bench protection.*

26 Instrument data label.

7.1 Preliminary operations

Remove the instrument from the packaging used for shipment and make an initial inspection of it. Check that the contents correspond to what was ordered.

If you notice any signs of tampering or damage, report it immediately to the SEITRON Service Center or its Representative Agent, retaining the original packaging.

A label attached to the instrument shows the serial number and model of the instrument.

It is recommended that both details be reported for any requests for technical intervention, spare parts or technical and application clarification.

Seitron maintains an archive at its headquarters with historical data on each instrument.

7.2 Instrument power supply

The instrument is normally powered with mains power, in the range 100 .. 240 V~, 50 .. 60 Hz, through the featured cable with IEC C14 plug.



**THE POWER SUPPLY/BATTERY CHARGER IS SWITCHING TYPE.
THE APPLICABLE INPUT VOLTAGE RANGES BETWEEN 100Vac AND 240Vac.
INPUT FREQUENCY: 50-60Hz.
LINE PROTECTION: 2 FUSES 4A T 5x20 SIZE**

7.3 WARNING



WARNING!

- **USE THE INSTRUMENT WITH AN AMBIENT TEMPERATURE BETWEEN -5° AND +45 °C OR 23 AND 113 °F.**
- **IF THE INSTRUMENT HAS BEEN KEPT AT VERY LOW TEMPERATURES (BELOW OPERATING TEMPERATURES) WE SUGGEST WAITING AT LEAST 1 HOUR BEFORE SWITCHING IT ON, IN ORDER TO HELP THE THERMAL BALANCE OF THE SYSTEM AND TO PREVENT CONDENSATE FORMING IN THE PNEUMATIC CIRCUIT.**
- **THE BACKUP BATTERY, WHICH KEEPS THE SENSORS POLARIZED, MAY BE POWER DRAINED IF THE INSTRUMENT IS LEFT UNUSED FOR A LONG PERIOD OF TIME CAUSING THE SENSORS DEPOLARIZATION, PARTICULARLY FOR THE OXIGEN (O₂) AND THE NITROGEN OXIDE (NO_x) SENSORS.
FOR THIS REASON, WHEN USING THE INSTRUMENT FOR THE FIRST TIME AND ANYWAY AFTER A TIME OF INACTIVITY WITHOUT POWER SUPPLY EXCEEDING 3 MONTHS, IT IS NECESSARY TO POWER THE INSTRUMENT FOR 24 HOURS BEFORE PROCEEDING TO ANY MEASURE AND/OR ANALYSIS, IN ORDER TO ALLOW THE BACKUP BATTERY TO RECHARGE AND TO THE SENSORS TO POLARIZE.
IF THIS PROCEDURE IS NOT PERFORMED, AFTER THE AUTOZERO CYCLE, THE OXIGEN SENSOR AND/OR THE NITROGEN OXIDE SENSOR COULD SHOW A CURRENT ERROR.**

- After use and before turning the instrument off remove the probe and let ambient clean air through it for at least 30 seconds in order to purge the pneumatic path from all residues of gas.
- Do not use the instrument if the filters are clogged or damp.
- Before placing the measuring probe back in its case after use, make sure it has cooled down enough and there is no condensate in the tube. It might be necessary to periodically disconnect the filter and the condensate separator and blow compressed air inside the tube to empty all residues.
- Remember to have the instrument checked and calibrated once a year in order to comply with the existing standards.



STARTING FROM 30 DAYS BEFORE THE ANNUAL CALIBRATION DEADLINE, THE DISPLAY WILL SHOW A MESSAGE REMINDING THE USER TO SEND THE INSTRUMENT TO THE SERVICE CENTER.

Example:



Press and hold for a few seconds

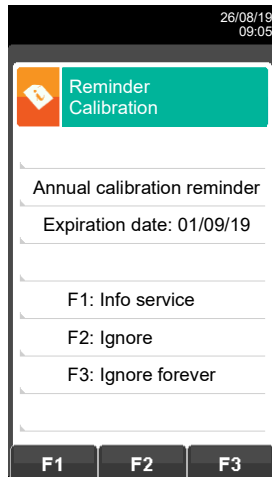

CONTEXT KEY	FUNCTION
F1	Shows all information relevant to service center.
F2	Temporarily ignores the message. At next turn-on of the instrument the reminder will be shown again.
F3	Permanently ignores the message.

8.1 Starting the device

As soon as it is powered the Instrument **DOES NOT** turn on automatically

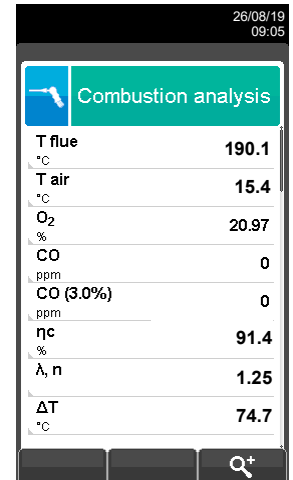
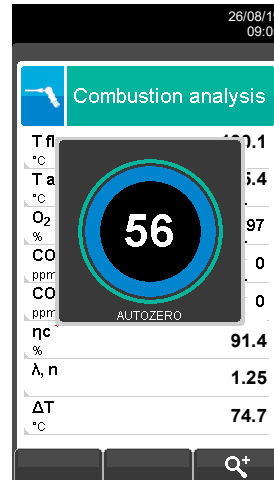

During autozero, it is possible to use only the menus that do not require autozero.

This error message is displayed if the autozero of the device is not successfully completed.

KEY	FUNCTION
	Activate the context keys shown on the display.
	Goes through the measurements available.
	Activates the context key located in the left side of the display.
	Returns to the previous screen.
	By keeping this button pressed for a few seconds, it turns ON or OFF the analyzer.

CONTEXT KEY	FUNCTION
	Repeats autozero (is shown in the case of an error).
	The device will suspend autozero and display the screen "Combustion Analysis"; it is possible to carry out the emission analysis (displayed in case of error).
	The device displays the screen "Sensor Diagnostics" (displayed in the case of an error).
	Zoom. By pressing this interactive key repeatedly, the device displays the following sequence: AAA → AAA → AAA → AAA

9.1 Configuration menu

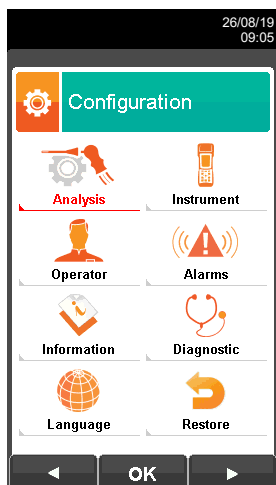

KEY	FUNCTION
	Activate the context keys shown on the display.
	Returns to the previous screen.

CONTEXT KEY	FUNCTION
	Selects the available parameters.
	Enters in the selected parameter setting.
	Selects the available parameters.

PARAMETER	DESCRIPTION
Analysis	Through this menu the user can configure the available parameters for a proper combustion analysis. SEE CHAPTER 9.2.
Instrument	This menu is used to configure the instrument's reference parameters. SEE CHAPTER 9.3.
Operator	In this sub menu you can enter or change the name of the operator that will carry out the analysis. Up to 8 lines are available. Also, you can select the name of the operator that will carry out the analysis and this will be printed on the analysis report. SEE CHAPTER 9.4.
Alarms	<p>Alarm management - In this submenu you have the possibility to set and store 1 alarm, for each one you can define the observed parameter (gas, pressure, Ta, Tf), the intervention threshold with its unit of measurement and whether it is an active alarm of minimum or maximum type. The alarm has the dedicated relay output 4.</p> <p>Description:</p> <p>The minimum type alarm will alert when the measurement falls below the set threshold, while the maximum type alarm will alert when the measurement rises above the set threshold. SEE CHAPTER 9.5.</p>
Information	This menu provides information regarding instrument status. SEE CHAPTER 9.6.
Diagnostic	L'utente, tramite questo menù, può verificare eventuali anomalie dello strumento. SEE CHAPTER 9.7.
Language	Imposta la lingua desiderata per la visualizzazione dei vari menù' e la stampa dello scontrino. SEE CHAPTER 9.14.
Restore	Ripristina i dati di impostati in fabbrica. SEE CHAPTER 9.15.

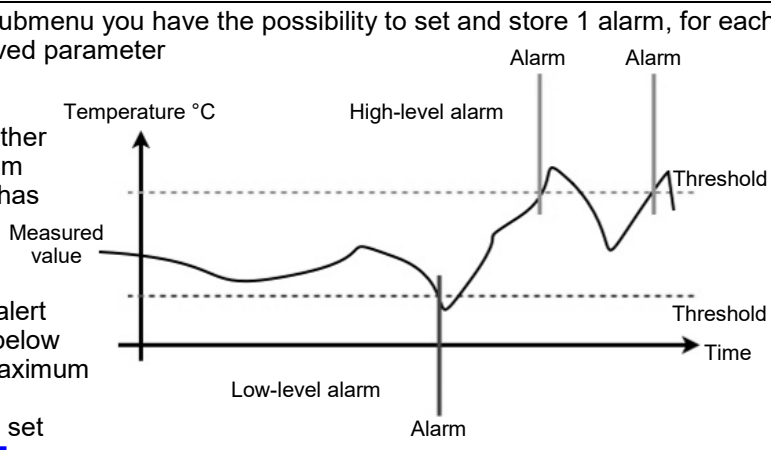

9.2 Configuration → Analysis

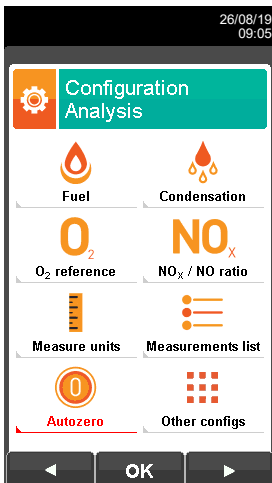
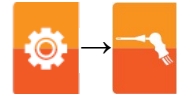



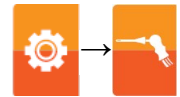

KEY	FUNCTION
	Activate the context keys shown on the display.
	Returns to the previous screen.

CONTEXT KEY	FUNCTION
	Selects the available parameters.
	Enters in the selected parameter setting.
	Selects the available parameters.

PARAMETER	DESCRIPTION
 Fuel	Lets the user select the type of fuel to be used during analysis. Fuel selection can be done either from this menu or during the analysis itself. By selecting the sub menu Fuel coefficients the user can view the characteristics of the fuels used in the calculation of performance. SEE SECTION 9.2.1.
 Condensation	The burner efficiency figure when condensation takes place is influenced by atmospheric pressure and humidity of the combustion air. As the atmospheric pressure is hardly precisely known, the operator is asked to enter a related parameter, i.e. the altitude of the place above the sea level, from which the pressure is then derived once the dependency from atmospheric conditions is neglected. In calculations the value of 101325 Pa is assumed as atmospheric pressure at sea level. Further the air relative humidity input is allowed, being this calculated at the combustion air temperature as measured from the instrument; in case this value is unknown the operator is recommended to enter 50% for this value. SEE SECTION 9.2.2.
 O ₂ reference	In this mode the user can set the oxygen percentage level to which pollutant emission values detected during analysis will be referenced. SEE SECTION 9.2.3.
 NO _x /NO ratio	NO _x /NO: all the nitrogen oxides which are present in the flue emissions (Nitrogen oxide = NO, Nitrogen dioxide = NO ₂); total nitrogen oxides = NO _x (NO + NO ₂). In the combustion processes, it is found out that the NO ₂ percentage contained in the gas is not far from very low values (3% or above); hence it is possible to obtain the NO _x value by a simple calculation without using a direct measurement with a further NO ₂ sensor. The NO ₂ percentage value contained in the gas can be however set at a value other than 3% (default value). This menu is only available when the NO ₂ sensor is not installed. SEE SECTION 9.2.4.



PARAMETER	DESCRIPTION
 <p>Measure units</p>	<p>Through this submenu the user can modify the measurement units for all the analysis parameters, depending on how they are used.</p> <p>SEE SECTION 9.2.5.</p>
 <p>Measures list</p>	<p>In this sub menu the user can see the list of measurements that the device can perform. With the interactive keys, the user can add, delete or move a selected measurement.</p> <p>SEE SECTION 9.2.6.</p>
 <p>Autozero</p>	<p>In this sub menu it is possible to modify the length of the autozero cycle, set the time related to the automatic cleaning cycle of the pneumatic circuit and configure the automatic autozero mode .</p> <p>SEE SECTION 9.2.7.</p>
 <p>Other configs</p>	<p>In this sub menu it is possible to set the part related to the sample treatment and the section of the pick up point of the sample to be analyzed.</p> <p>SEE SECTION 9.2.8.</p>

9.2.1 Configuration → Analysis → Fuel

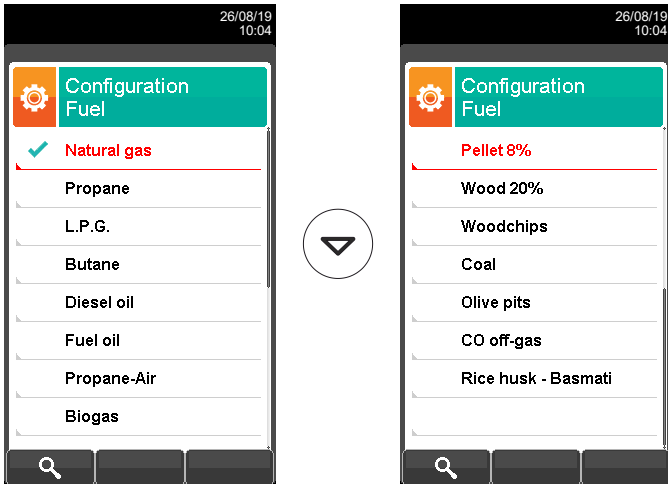
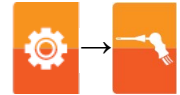

KEY	FUNCTION
	Activate the context keys shown on the display.
	The arrows select each line displayed.
	Confirms the choice of fuel to be used during the analysis.
	Returns to the previous screen.

CONTEXT KEY	FUNCTION
	Shows the details of the selected fuel (see example below).
	Returns to the previous screen.

Example:

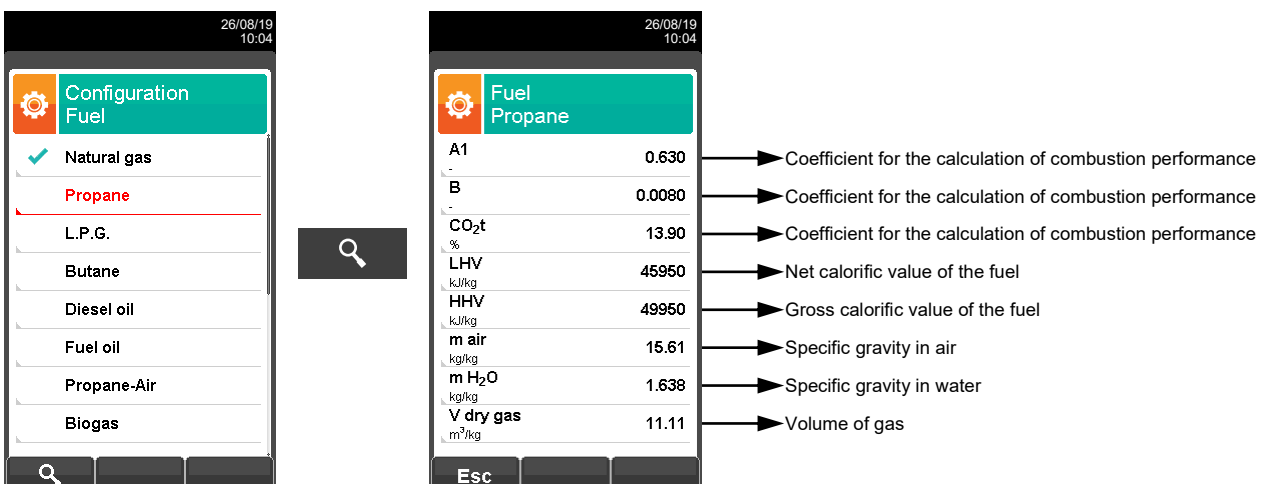

9.2.2 Configuration → Analysis → Condensation

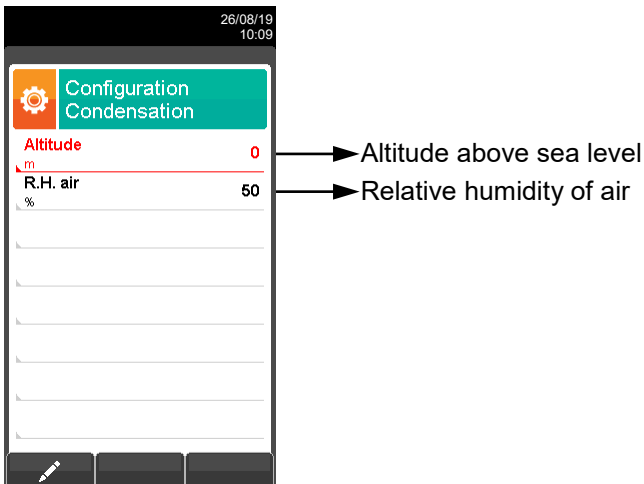
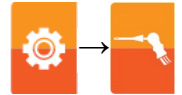

KEY	FUNCTION
	Activate the context keys shown on the display.
	The arrows select each line displayed (the selected line is red). In edit mode, it scrolls through the suggested values.
	Enters the modify mode for the selected parameter, then confirms the modification.
	When pressed in modify mode cancels the selection made, otherwise returns to the previous screen.

CONTEXT KEY	FUNCTION
	Enters the modification mode for the selected parameter.
	Confirms the modification.

Example:

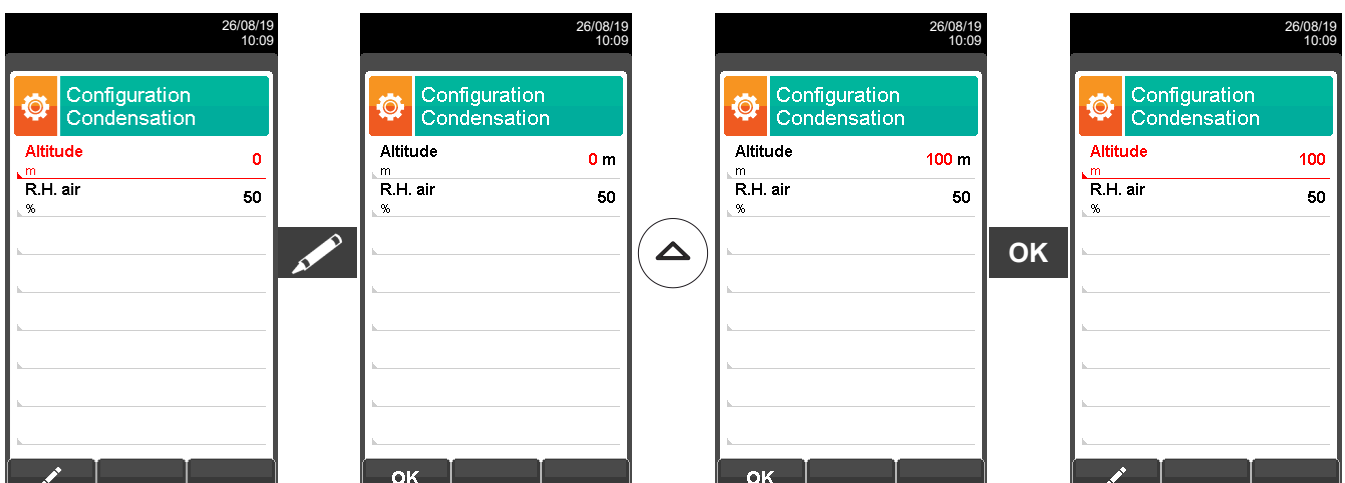

9.2.3 Configuration → Analysis → Reference O₂

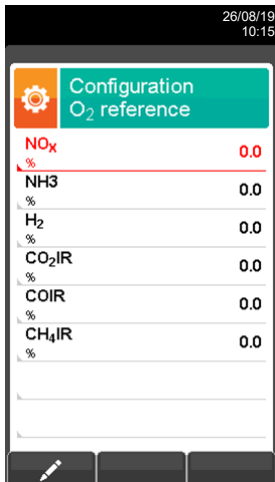
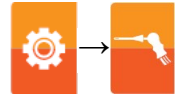

- Oxygen rate on NO_x measurement
- Oxygen rate on NH₃ measurement
- Oxygen rate on H₂ measurement
- Oxygen rate on CO₂ measurement
- Oxygen rate on CO measurement
- Oxygen rate on CH₄ measurement

KEY	FUNCTION
	Activate the context keys shown on the display.
	Keys '▲' and '▼' select any line shown on the display (the selected line is displayed in red). When in modify mode, sets the desired value.
	Enters the modify mode for the selected parameter, then confirms the modification.
	When pressed in modify mode cancels the selection made, otherwise returns to the previous screen.

CONTEXT KEY	FUNCTION
	Enters the modify menu for the selected parameter.
	Confirms the modification.

Example:

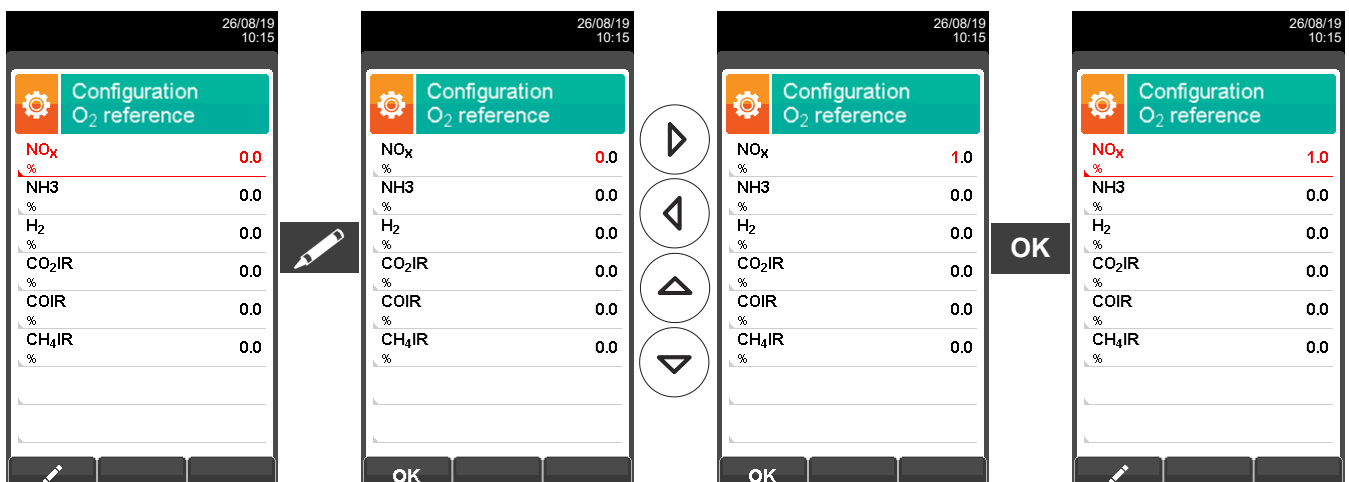

9.2.4 Configuration → Analysis → NO_x/NO ratio

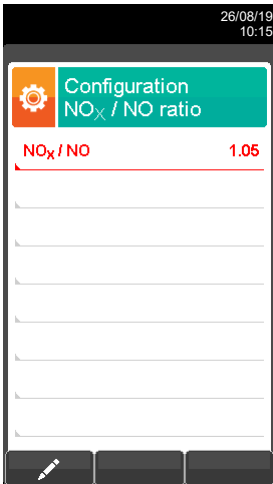
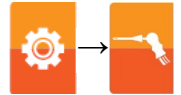

KEY	FUNCTION
	Activate the context keys shown on the display.
	When in modify mode, sets the desired value.
	Enters edit mode of the selected element and then confirms the change.
	When pressed in modify mode cancels the selection made, otherwise returns to the previous screen.

CONTEXT KEY	FUNCTION
	Enters edit mode.
	Confirms the modification.

Example:

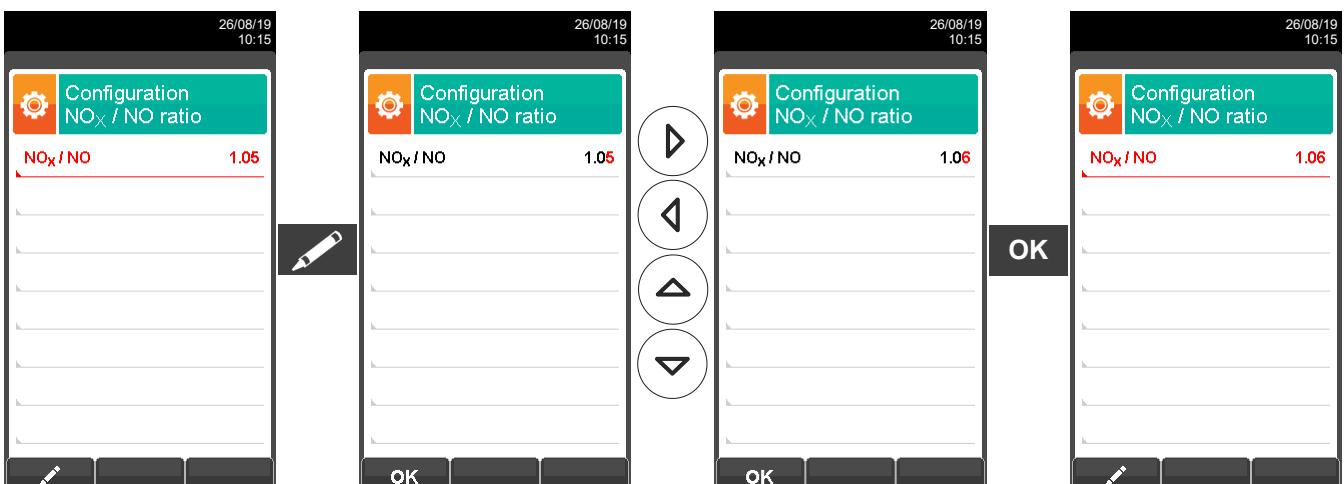

9.2.5 Configuration → Analysis → Measurement units

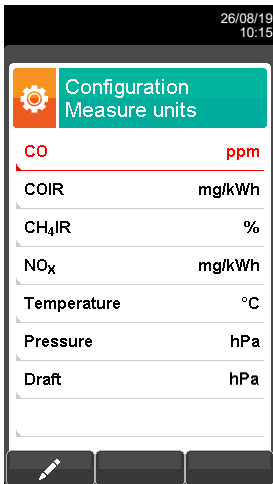
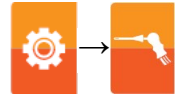

- Measurement unit can be set as: ppm - mg/m³ - mg/kWh - g/GJ - g/m³ - g/kWh - % - ng/J
- Measurement unit can be set as: ppm - mg/m³ - mg/kWh - g/GJ - g/m³ - g/kWh - % - ng/J
- Measurement unit can be set as: ppm - mg/m³ - mg/kWh - g/GJ - g/m³ - g/kWh - % - ng/J
- Measurement unit can be set as: ppm - mg/m³ - mg/kWh - g/GJ - g/m³ - g/kWh - % - ng/J
- Measurement unit can be set as: °C - °F
- Measurement unit can be set as: hPa - Pa - mbar - mmH2O - mmHg - inH2O - psi
- Measurement unit can be set as: hPa - Pa - mbar - mmH2O - mmHg - inH2O - psi

The measurement units mg/m³ and g/m³ are referred to Normal pressure and temperature conditions, P = 101325 Pa and T = 0 °C.

KEY	FUNCTION
	Activate the context keys shown on the display.
	Keys '▲' and '▼' select any line shown on the display (the selected line is displayed in red). When in modify mode, sets the desired value.
	Enters edit mode of the selected element and then confirms the change.
	When pressed in modify mode cancels the selection made, otherwise returns to the previous screen.

CONTEXT KEY	FUNCTION
	Enters the modification mode for the selected parameter.
	Confirms the modification.

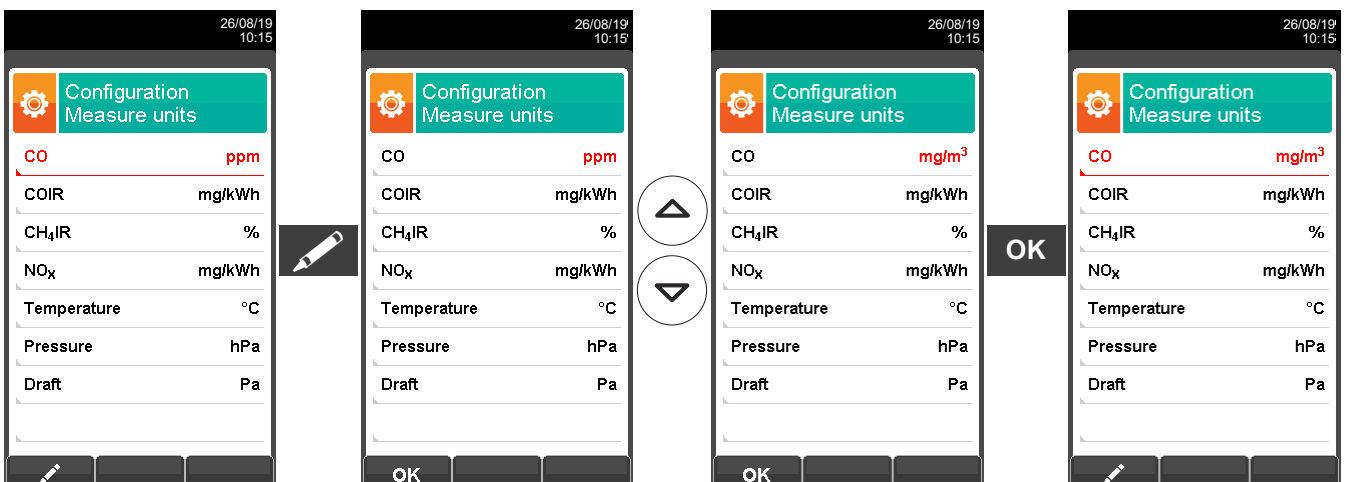

Example:



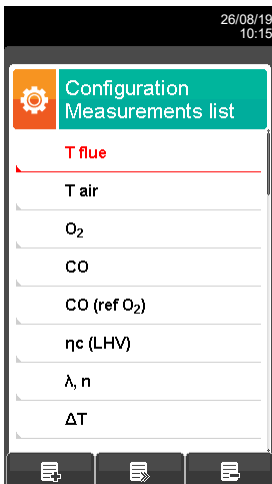
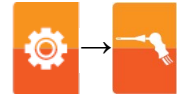



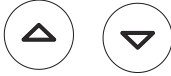



9.2.6 Configuration → Analysis → Measurements list



 FOR FURTHER DETAILS SEE THE [ANNEX C](#)

KEY	FUNCTION
	Activate the context keys shown on the display.
	Select each line displayed (the line selected is red). In edit mode, it sets the desired value.
	When pressed in modify mode cancels the selection made, otherwise returns to the previous screen.

CONTEXT KEY	FUNCTION
	Adds a line to the list of available measurements.
	Activates the movement of a measurement from its current position.
	Deletes a measurement from the list of available measurements.
	After the activation of the function '  ': It scrolls through the available measurements. After the activation of the function '  ': It moves the element from its current position.
	Confirms the operation.
	Cancel the operation.

 OTHER THAN THE MEASUREMENT LIST ABOVE, IT IS POSSIBLE TO VISUALIZE THE MEASURE OF THE DETECTED GAS ALSO IN PPM, DEPENDING ON THE KIND OF MEASUREMENT CELL IN THE INSTRUMENT. IF IT IS NECESSARY TO MEASURE THE VALUE OF GAS WITH TWO DIFFERENT MEASUREMENT UNITS, SELECT IN THE MEASUREMENTS LIST THE DESIRED GAS IN PPM AND CHANGE THE MEASUREMENT UNIT FOR THE SAME GAS IN THE "CONFIGURATION->ANALYSIS->MEASUREMENT UNIT" SCREEN. NOW THE INSTRUMENT ACQUIRES THE MEASURE WITH TWO DIFFERENT UNITS (PPM AND THE ONE PREVIOUSLY SET).

Example:

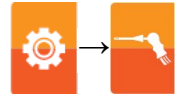

1. Add a measurement to the list - example

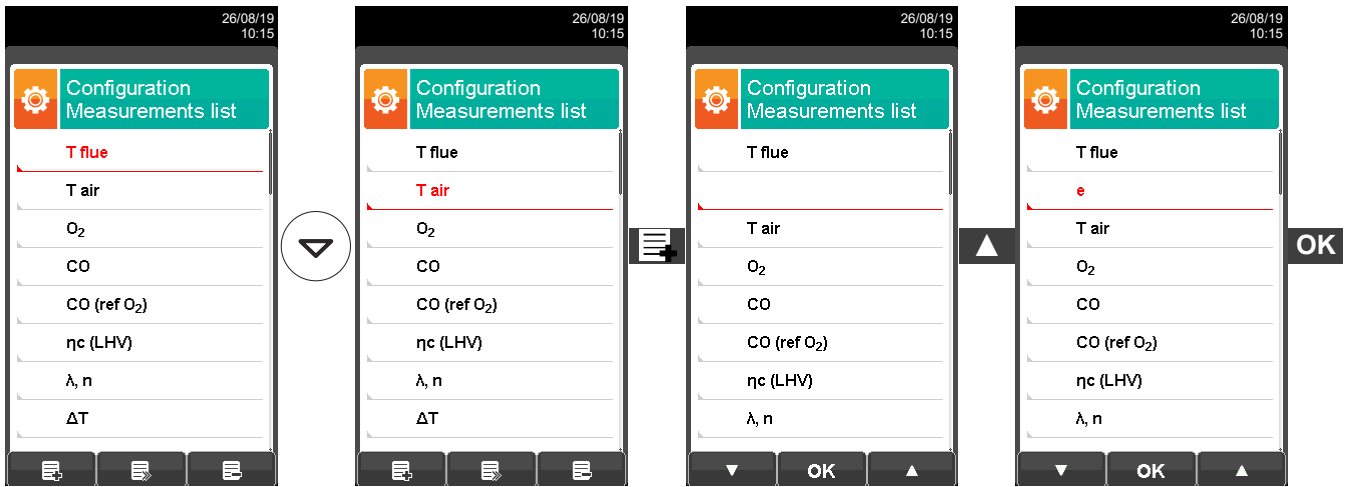

2. Change the position of a measurement - example

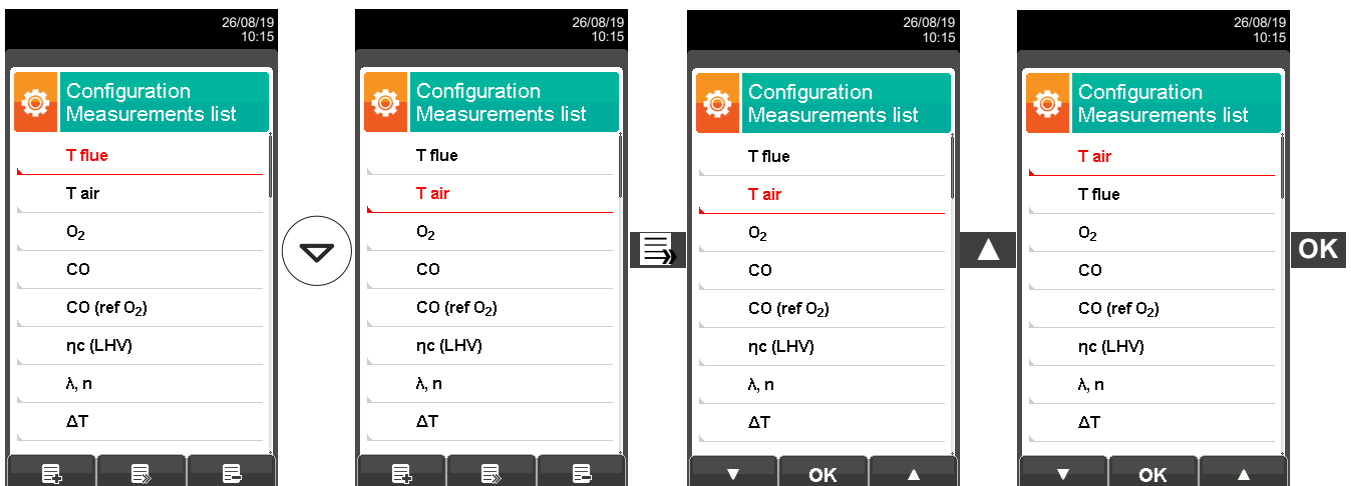

3. Delete a measurement from the list - example

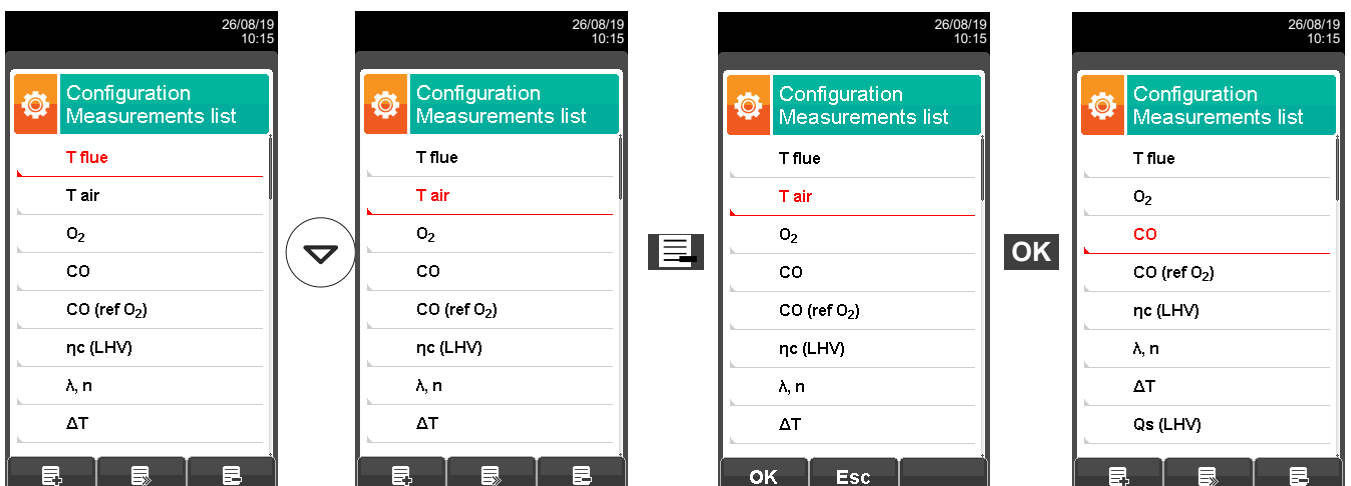

9.2.7 Configuration → Analysis → Autozero

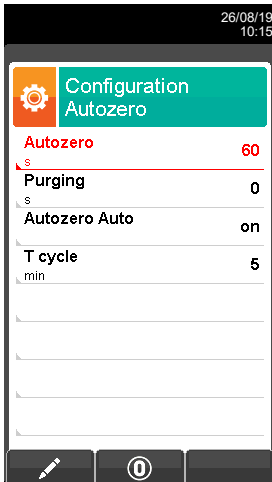
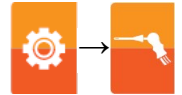

- Duration of autozero, expressed in seconds.
- Duration of the cleaning cycle, expressed in seconds.
- Turns On / Off the automatic autozero of the instrument.
- Setting of the time interval between an autozero and the next, expressed in minutes: 0 .. 1440 min.
This parameter is only visible if the option "Autozero Auto" is set to "On".

KEY	FUNCTION
	Activate the context keys shown on the display.
	The arrows '▲' and '▼' select each line displayed (the selected line is highlighted in red). When in modify mode, sets the desired value.
	Enters edit mode of the selected element and then confirms the change.
	When pressed in modify mode cancels the selection made, otherwise returns to the previous screen.

CONTEXT KEY	FUNCTION
	Enters the modify menu for the selected parameter.
	Confirms the modification.
	Starts autozero for the selected duration.

Example:

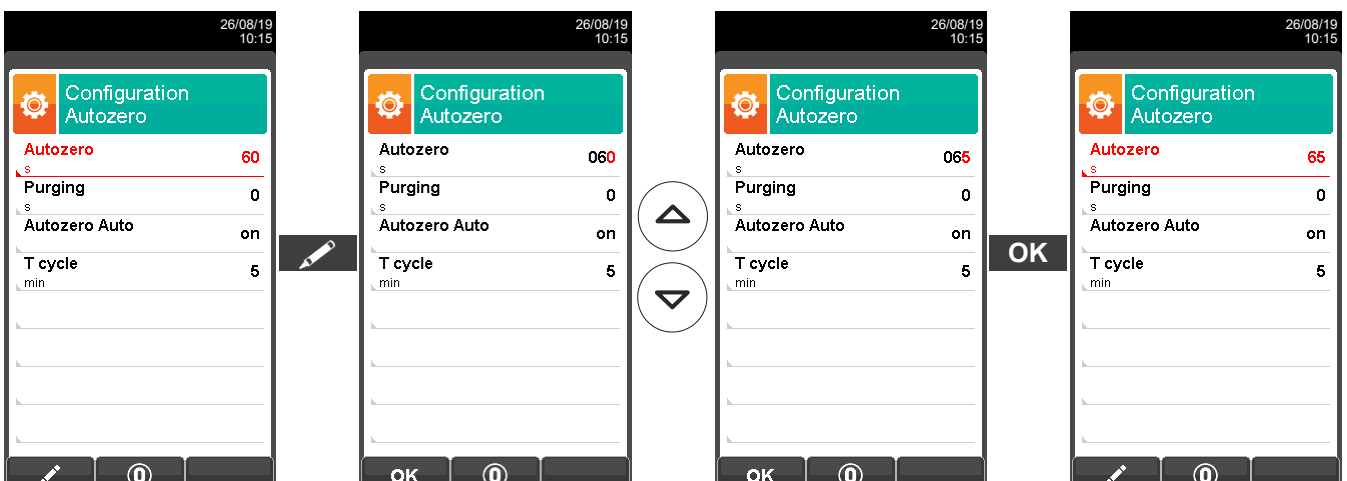

9.2.8 Configuration → Analysis → Other configs

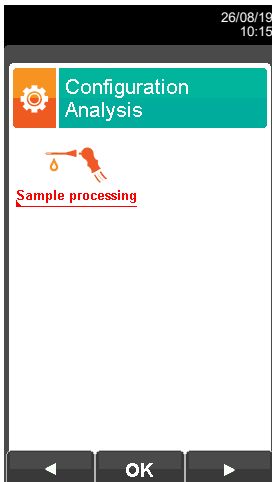
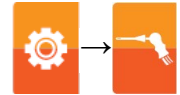

KEY	FUNCTION
	Activate the context keys shown on the display.
	Returns to the previous screen.

CONTEXT KEY	FUNCTION
	Selects the available parameters.
	Enters the selected parameter.
	Selects the available parameters.

PARAMETER	DESCRIPTION
 Sample processing	In this parameter it is possible to activate/deactivate the cooler. Furthermore, it is possible to set the temperature of the heated hose. The activation of the Cooler is shown on the display with the icon "  ". SEE SECTION 9.2.9.

9.2.9 Configuration → Analysis → Sample processing

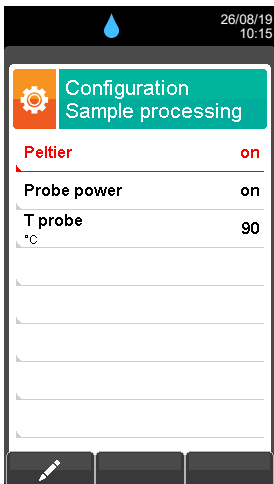
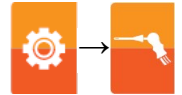

- Available settings: on (Cooler is switched on) or off (Cooler is switched off).
- Available settings: on (Heated Tube switched on) or off (Heated Tube switched off).
- Heated tube temperature: 194°F .. 266°C.

WARNING

The activation of the Cooler system is indicated on the display with the icon “”

KEY	FUNCTION
	Activate the context keys shown on the display.
	The arrows '▲' and '▼' select each line displayed (the selected line is highlighted in red). When in modify mode, sets the desired value.
	Enters the modify mode, then confirms the modification.
	When pressed in modify mode, it cancels the selection made or returns to the previous screen.

CONTEXT KEY	FUNCTION
	Enters the modification mode for the selected parameter.
	Confirms the modification.

Example:

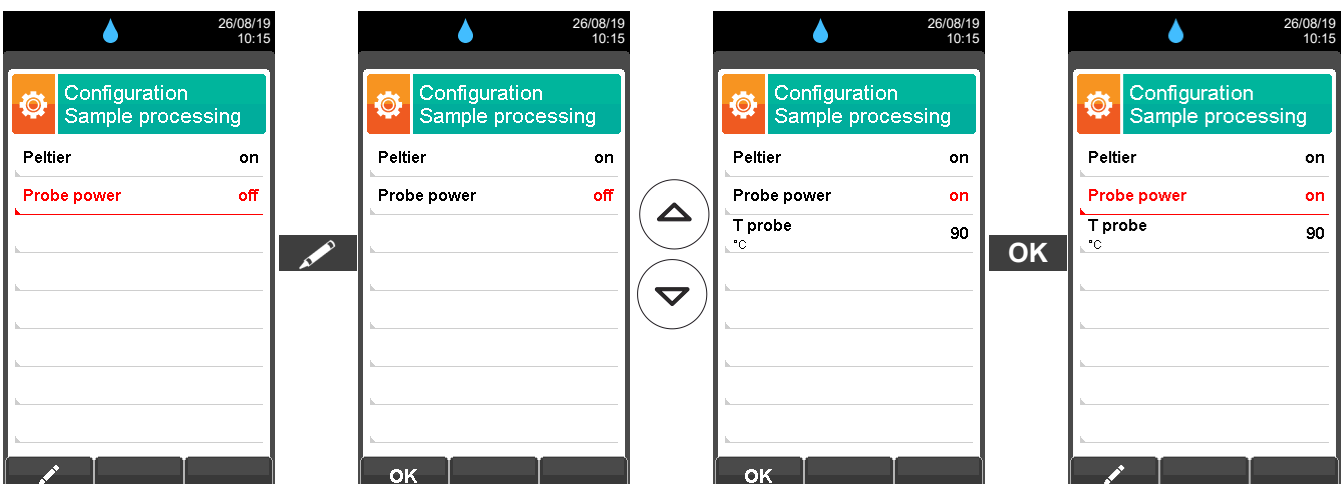

9.3 Configuration→Instrument

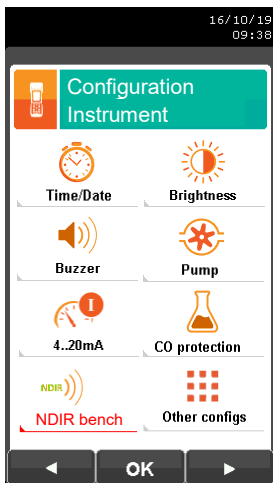

KEY	FUNCTION
	Activate the context keys shown on the display.
	Returns to the previous screen.

CONTEXT KEY	FUNCTION
	Selects the available parameters.
	Enters in the selected parameter setting.
	Selects the available parameters.

PARAMETER	DESCRIPTION
Time/Date	This allows the current time and date to be set. The user can select the date and hour format either in EU (European) or USA (American) mode. SEE CHAPETER 9.3.1.
Brightness	The display brightness may be increased or decreased by acting on cursor keys. This operation may be performed even when the introductory screen is active. SEE CHAPETER 9.3.2.
Buzzer	The instrument is fitted with an internal buzzer which is mainly used to signal any faults and/or alarms. In this submenu you can enable or disable the buzzer or enable it and mute the key tones. SEE CHAPETER 9.3.3.
Pump	In this submenu it is possible turn on/off the smoke suction pump. Moreover, if the pump is on, the gas flow of the pump measured in liters per minute will be visible. It is not possible to turn off the pump while the autozero cycle is being performed. SEE CHAPETER 9.3.4.
4..20mA	The instrument features eight 4..20mA output channels. In this submenu it is possible to associate to each channel one measure among the ones that the instrument is able to provide, aiming to translate a measure in a current value available as an output. Moreover, it is possible to adjust the measurement field and by doing so, heighten the output resolution. SEE CHAPETER 9.3.5.
CO protection	The CO sensor is protected by a pump which, in case of need, can inject clean air in the gas path in order to dilute the gas concentration measured by the sensor. This function can either be triggered by the overcoming of a CO concentration threshold which can be set by the user or, in case it is known that the flue gases contain high CO concentration, kept enabled at all times, independently of CO concentration. Activation of the dilution pump is indicated on the display by the icon "". <div style="border: 1px solid black; padding: 5px; text-align: center;"> DILUTION SHOULD BE UNDERSTOOD AS A PROTECTION OF THE CO SENSOR AGAINST OVER-SATURATION AS IT SEVERELY DETERIORATES THE ACCURACY AND RESOLUTION OF THE MEASUREMENT. </div> SEE CHAPETER 9.3.6.
NDIR Bench	Enables (on) or disables (off) the NDIR bench. SEE CHAPETER 9.3.7.
Other configs	In this submenu, you can configure the part related to the MODBUS® module. SEE CHAPETER 9.3.8.

9.3.1 Configuration→Instrument→Time/Date

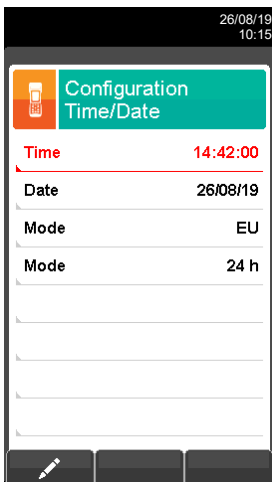

- Time, in the chosen format
- Date, in the chosen format
- Date format: EU (Europe) or USA (America)
- Time format: 24h or 12h

KEY	FUNCTION
	Activate the context keys shown on the display.
	The arrows '▲' and '▼' select each line displayed (the selected line is highlighted in red). When in modify mode, sets the desired value.
	Enters edit mode of the selected element and then confirms the change.
	When pressed in modify mode cancels the selection made, otherwise returns to the previous screen.

CONTEXT KEY	FUNCTION
	Enters edit mode of the selected parameter.
	Confirms the modification.

9.3.2 Configuration→Instrument→Brightness

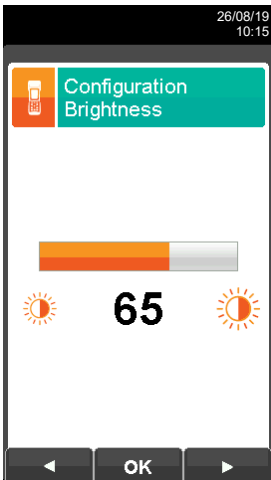

KEY	FUNCTION
	Activate the context keys shown on the display.
	Increases or decreases the brightness of the display.
	Confirms the modification.
	When pressed in modify mode cancels the selection made, otherwise returns to the previous screen.

CONTEXT KEY	FUNCTION
	Decreases the brightness of the display.
	Confirms the setting.
	Increases the brightness of the display.

9.3.3 Configuration→Instrument→Buzzer

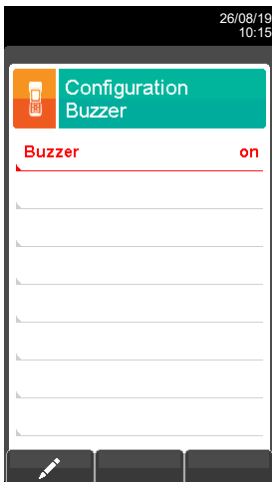

Available settings:

- on:** the buzzer is enabled (key tones and signaling of faults/alarms are enabled).
- limited:** the buzzer is enabled in a limited mode (key tones are disabled, while signaling of faults/alarms is enabled).
- off:** the buzzer is disabled.

KEY	FUNCTION
	Activate the context keys shown on the display.
	When in modify mode, sets the desired value.
	Enters edit mode of the selected element and then confirms the change.
	When pressed in modify mode cancels the selection made, otherwise returns to the previous screen.

CONTEXT KEY	FUNCTION
	Enters edit mode of the selected parameter.
	Confirms the modification.

9.3.4 Configuration→Instrument→Pump

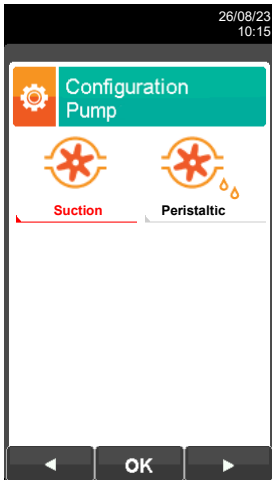

KEY	FUNCTION
	Activate the context keys shown on the display.
	When in modify mode, sets the desired value.
	Enters edit mode of the selected element and then confirms the change.
	When pressed in modify mode cancels the selection made, otherwise returns to the previous screen.

CONTEXT KEY	FUNCTION
	Enter edit mode: it is possible to turn off/on the smoke suction pump or change the peristaltic pump turn-on time.
	Confirm the option selected.
	Holding down the key, decreases the pump flow.
	Holding down the key, increases the pump flow.

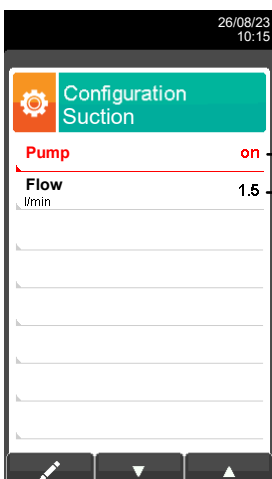

Available choices: on (pump on) or off (pump off).

Display of pump flow rate, expressed in Liters/minute.

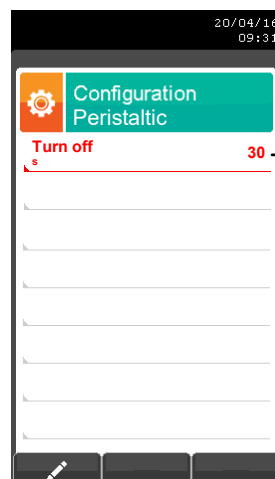

Sets the time for the peristaltic pump to turn off.

9.3.5 Configuration → Instrument → 4..20mA

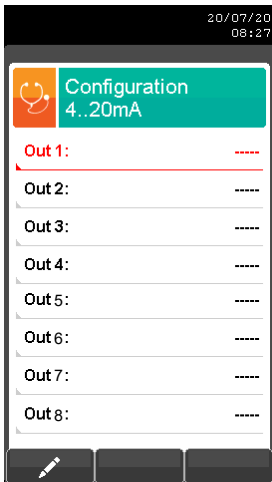

“----”: Channel NOT configured (default setting).
 “OK”: Channel configured.

WARNING

- If the measurement unit of the observed parameter is changed, it is necessary to reconfigure the set limits.
- If the parameter “Limits” is set to manual, the suggested values are the ones related to the automatic setting.
- If an output is set to manual and it is needed to set it back to default values, it is necessary to set the “Limits” parameter to auto.

Example related to output 1:

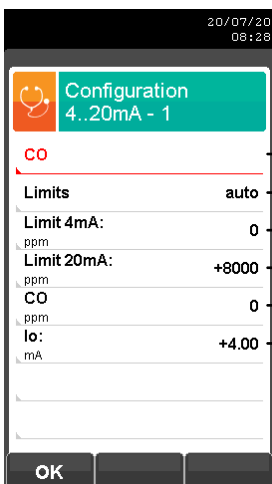

Select the measure that the instrument can perform.

Limits settings: **auto** - the lower limit (4mA) and the upper limit (20mA) are automatically set by the instrument depending on the observed parameter and it is not settable by the user or **manual** - the lower limit (4mA) and the upper limit (20mA) are settable by the user inside the range of the observed parameter.

Lower limit (4mA) settable only if the parameter limit is set to “manual”.

Upper limit (20mA) settable only if the parameter limit is set to “manual”.

This row shows the measure value in real time.

This row shows the output current value in real time (inside the range 4..20mA).

KEY	FUNCTION
	Activate the context keys shown on the display.
	Keys '▲' and '▼' select any line shown on the display (the selected line is displayed in red). When in modify mode, sets the desired value.
	Enters edit mode of the selected element and then confirms the change.
	When pressed in modify mode cancels the selection made, otherwise returns to the previous screen.

CONTEXT KEY	FUNCTION
	Enters edit mode of the selected parameter.
	Confirms the modification.

9.3.6 Configuration → Instrument → CO Protection

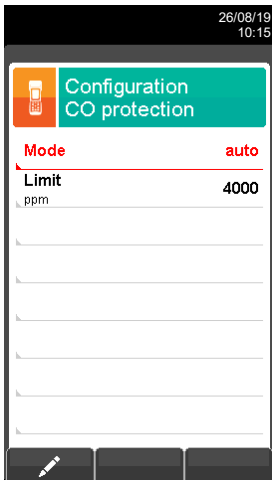

- ▶ Available settings: auto, on or off
- ▶ Threshold that activates the CO sensor protection (available only if the parameter "Mode" is set to "auto").

WARNING!
The activation of the CO sensor protection is shown on the display with the icon "".

KEY	FUNCTION
	Activate the context keys shown on the display.
	Select each line displayed (the line selected is red). In edit mode, it sets the desired value.
	Enters edit mode of the selected element and then confirms the change.
	When pressed in modify mode cancels the selection made, otherwise returns to the previous screen.

CONTEXT KEY	FUNCTION
	Enters edit mode of the selected parameter.
	Confirms the modification.

9.3.7 Configuration→Instrument→NDIR Bench



KEY	FUNCTION
	Activate the context keys shown on the display.
	In edit mode, it sets the desired value.
	Enters edit mode of the selected element and then confirms the change.
	When pressed in modify mode cancels the selection made, otherwise returns to the previous screen.

CONTEXT KEY	FUNCTION
	Enters edit mode of the selected parameter.
	Confirms the modification.

NDIR BENCH AACSE38 AND AACSE76

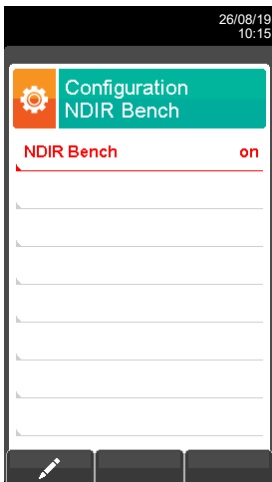

Available settings: **on**: NDIR bench is enabled - **off**: NDIR bench is disabled.

WARNING
In order to make effective the new configuration, please turn the instrument off and then on again.

NDIR BENCH AACSE80 FOR HEAT TREATMENT

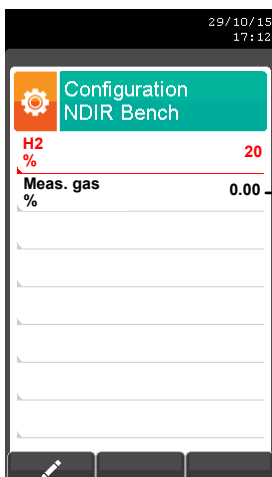

Set the concentration value of H₂

CO₂ gas measurement in the current analysis

CAUTION
This configuration is used to set the value of hydrogen concentration present in the metal heat treatment process. It allows the instrument to perform proper compensation of the CO₂ measurement by entering a value between 24 to 60.
Note: When performing cal on site this value must be at 24; when calibration is completed it is reset to the set value.

9.3.8 Configuration → Instrument

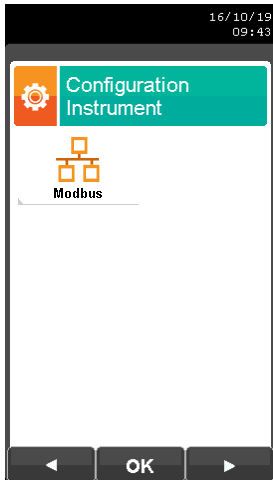

KEY	FUNCTION
	Activate the context keys shown on the display.
	Returns to the previous screen.

CONTEXT KEY	FUNCTION
	Select the available parameters.
	Enters the selected parameter.
	Select the available parameters.

PARAMETER	DESCRIPTION
	<p>The instrument is featured with the serial output RS485 which is used to connect the instrument to the PC, through the communication protocol MODBUS[®] RTU. This submenu allows to set the data related to the MODBUS[®] communication. For further information on the available register table it is necessary to ask the local dealer.</p> <p>SEE CHAPTER 9.3.9.</p>

9.3.9 Configuration → Instrument → Modbus

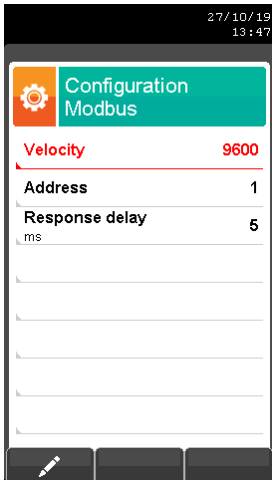

- Communication speed (Available options: **4800 - 9600 - 19200 - 38400**).
- Address that identifies the instrument in the MODBUS[®] protocol.
- Answer delay to the slave device call.

WARNING

- When the MODBUS parameters are modified, it is necessary to reboot the instrument.
- The instrument reboot must be performed by pressing the on/off key on the front cover; it is not necessary to physically cut off mains power by disconnecting the power cable plug.

KEY	FUNCTION
	Activate the context keys shown on the display.
	In edit mode, it sets the desired value.
	Enters edit mode of the selected element and then confirms the change.
	When pressed in modify mode cancels the selection made, otherwise returns to the previous screen.

CONTEXT KEY	FUNCTION
	Enters edit mode of the selected parameter.
	Confirms the modification.

9.4 Configuration → Operator

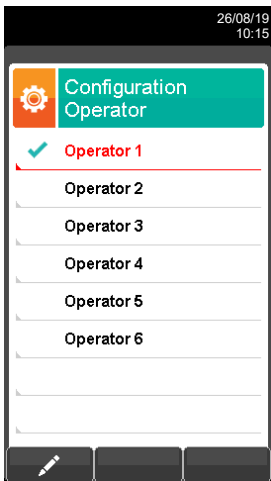
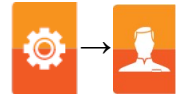

KEY	FUNCTION
	Activate the context keys shown on the display.
	In "edit text": Moves the cursor on the box corresponding to the letter or number required to form the word.
	In "Operator Configuration": Scrolls through the available operators.
	In "edit text": Confirms text input. In "Operator Configuration": selects the operator who will carry out the analysis; the operator is highlighted with the symbol "✓".
	Returns to the previous screen. In "edit text" mode returns to the previous screen without saving the changes.

CONTEXT KEY	FUNCTION
	Enters edit mode of the selected line: it is possible to enter the name of the operator (24 characters available).
	Confirms the selected letter or digit.
	Cancel the letter or digit before the cursor.
	Cycles through uppercase, lowercase, symbols and special characters.

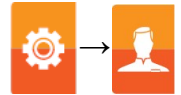

Example:

1. Edit text

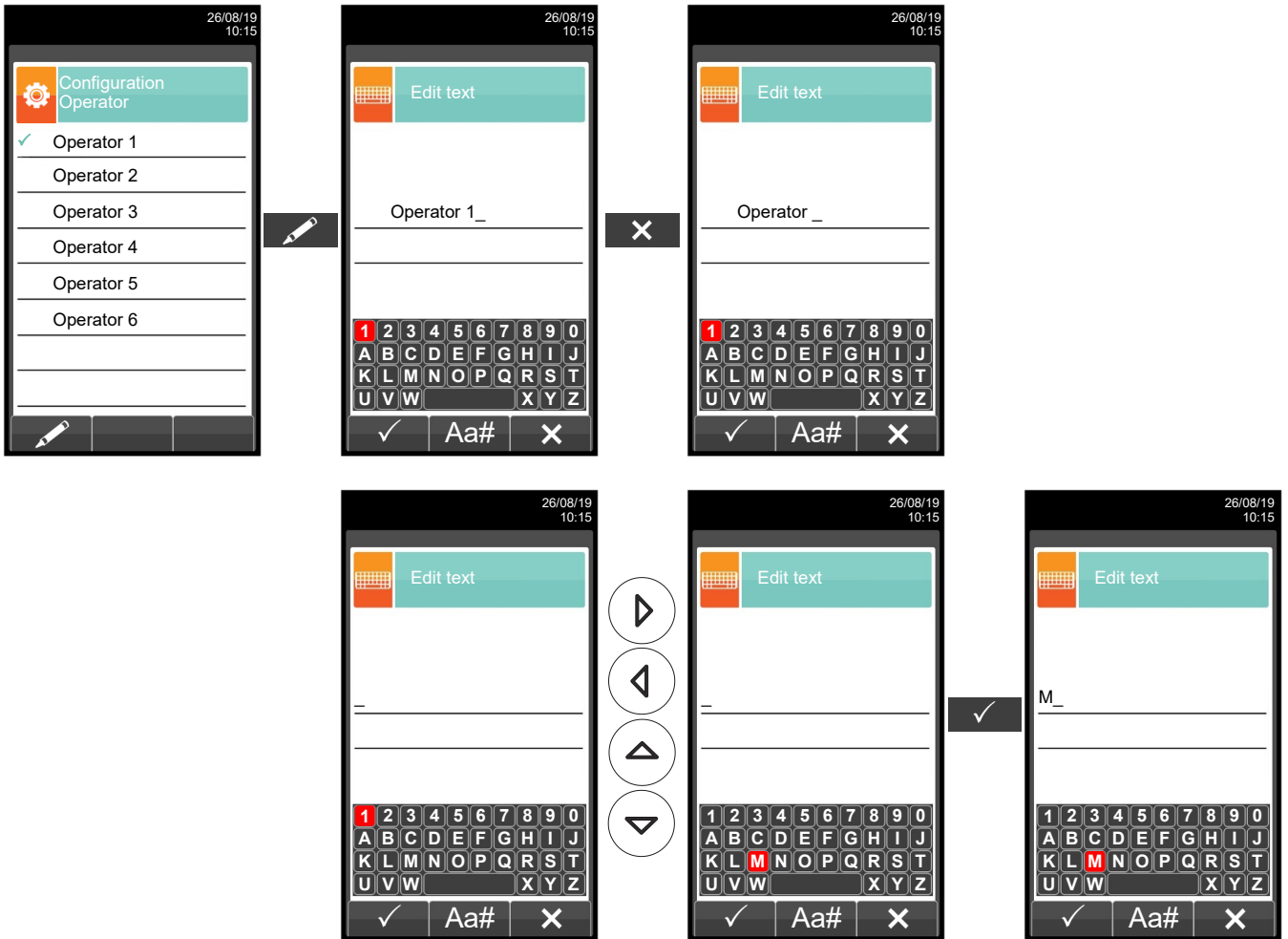

2. Select the operator who will carry out the analysis

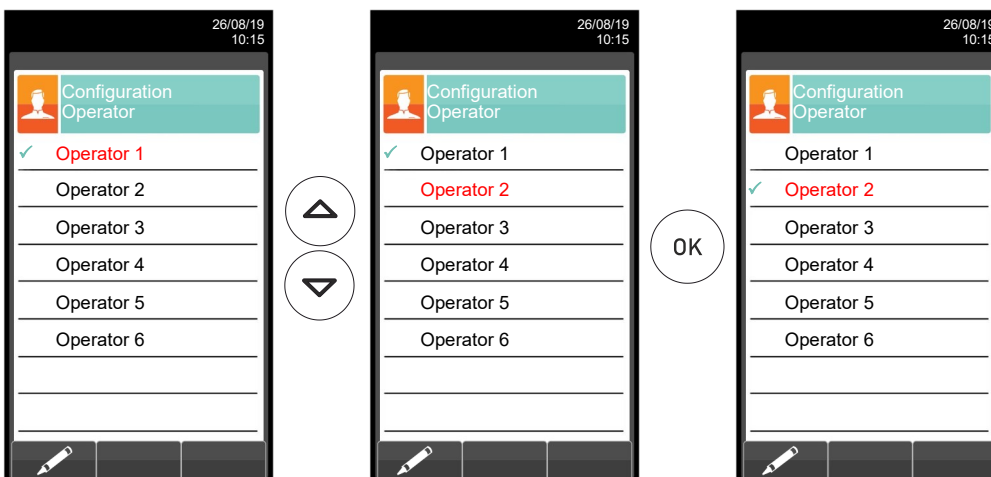

9.5 Configuration → Alarms

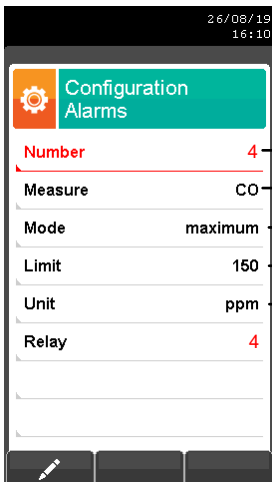

- Configured alarm number
- Monitored parameter: O₂ - CO - NO - NO₂ - P diff - Plow - P ext - T1 - T2 - Or alarm 7-10*¹ - Or alarm 7-10 Inv*² - autozero in progress
- Type of alarm set: maximum - minimum - off
- Threshold setting for the previously set alarm: ±999999.999
- Measurement unit for the threshold set: ppm, mg/m³, mg/kWh, g/GJ, g/m³, g/kWh, %, ng/J
- Note: The instrument has only one relay output, number 4

KEY	FUNCTION
	Activate the context keys shown on the display.
	Keys '▲' and '▼' select any line shown on the display (the selected line is displayed in red). When in modify mode, sets the desired value.
	Enters the modify mode for the selected parameter, then confirms the modification.
	When pressed in modify mode cancels the selection made, otherwise returns to the previous screen.

CONTEXT KEY	FUNCTION
	Enters the modify menu for the selected parameter.
	Confirms the modification.

*¹ : The alarm is triggered if one of the alarm thresholds set by number 7 to number 10 is exceeded.
Relay 4 is powered by connecting terminal 6 with 8 of the rear 37-pin CONN 1 connector.

*² : The alarm is triggered if one of the alarm thresholds set by number 7 to number 10 is exceeded.
The relay is energized; if the alarm trips, relay 4 is de-energized by connecting terminal 6 with terminal 7 of the rear 37-pin CONN 1 connector.



Alarm activation flow chart and suggested correctional actions

Type MAX. alarm activation

Type MIN. alarm activation

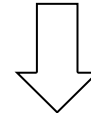
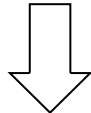

- Buzzer activation.
- The measure blinks on the display.
- Relay activation.

- Buzzer activation.
- The measure blinks on the display.
- Relay activation.

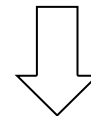
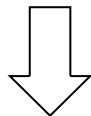

- Regulate the boiler correctly.
- The alarm is switched off automatically, if the gas concentration goes back below the set alarm threshold minus the hysteresis value.

- Regulate the boiler correctly.
- The alarm is switched off automatically, if the gas concentration is higher than the set alarm threshold plus the hysteresis value.

9.6 Configuration → Information

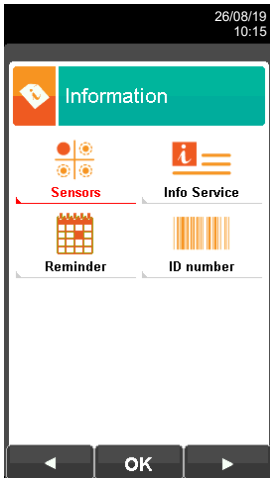
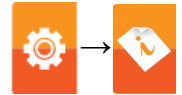

KEY	FUNCTION
	Activate the context keys shown on the display.
	Returns to the previous screen.

CONTEXT KEY	FUNCTION
	Selects the available parameters.
	Enters in the selected parameter setting.
	Selects the available parameters.

PARAMETER	DESCRIPTION
 Sensors	Allows to check which sensors are installed on the instrument, and in which position they are installed on. The instrument automatically detects whether a sensor has been either added or removed. The screen page allows whether to accept the new configuration or ignore the change performed. SEE SECTION 9.6.1.
 Info Service	This submenu contains details regarding the nearest Service Center to be contacted in the event of instrument fault or ordinary maintenance. The instrument model, serial number and firmware version are also displayed, thus allowing for a quick product identification. SEE SECTION 9.6.2.
 Reminder	In this menu the user can see the reminder of the instrument annual calibration that was entered in the factory or in the service center. The menu is protected by the following password: " 2908 ". SEE SECTION 9.6.3.
 ID number	Not available.

9.6.1 Configuration→Information→Sensors

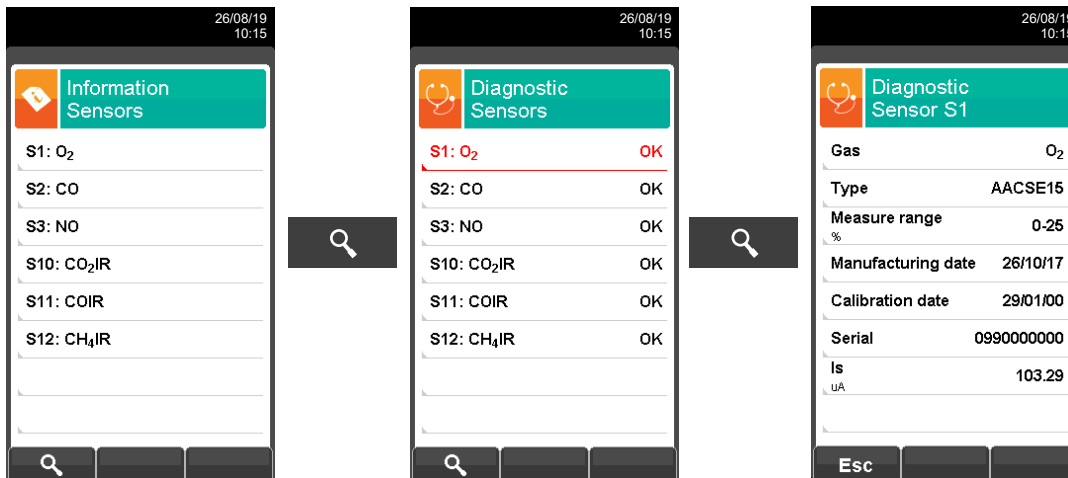
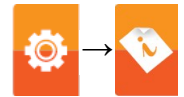

For further information [see section 9.7.](#)

KEY	FUNCTION
	Activate the context keys shown on the display.
	Returns to the previous screen.

CONTEXT KEY	FUNCTION
	Displays the details of the main features of the sensors installed.
	Returns to the previous screen.

This screen displays, for each position, the following messages:

MESSAGE	DESCRIPTION
OK	Sensor configured OK (normal operation).
-----	Sensor is not communicating or has been removed. For sensors in positions 10, 11 and 12: NDIR bench is not installed or has been disabled or measure not enabled.
<i>The name of the detected gas is flashing</i>	New sensor detected.
Pos err	Detected sensor in wrong position.
Volt err	Detected voltage is out of the normal operating range; repeat the autozero.
Curr err	Detected current is out of the normal operating range; repeat the autozero.
Err autozero	NDIR bench autozero failed.

Error messages displayed:

MESSAGE	DESCRIPTION
Cal err	Calibration error.
Data err	Sensor not recognized.
No cal	Sensor not calibrated.

9.6.2 Configuration → Information → InfoService

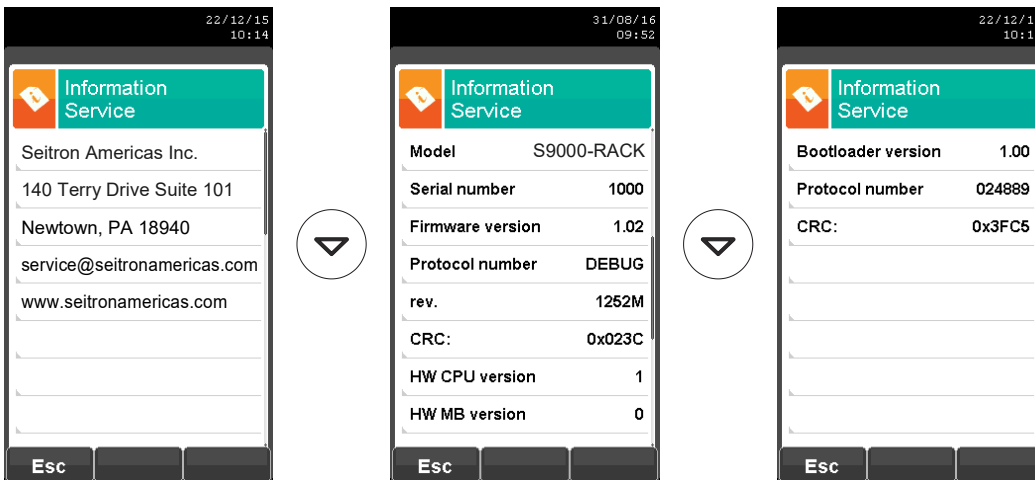

KEY	FUNCTION
	Activate the context keys shown on the display.
	Returns to the previous screen.

CONTEXT KEY	FUNCTION
	Returns to the previous screen.

9.6.3 Configuration→Information→Reminder



KEY	FUNCTION
	Activate the context keys shown on the display.
	Sets the password to access the remainder menu. The password is: 2908.
	Returns to the previous screen.

CONTEXT KEY	FUNCTION
	Shows details about the main features of the sensors installed.
	Returns to the previous screen.
	Shows all information relevant to service center.
	Temporarily ignores the message. At next turn-on of the instrument the reminder will be shown again.
	Ignores the message permanently.

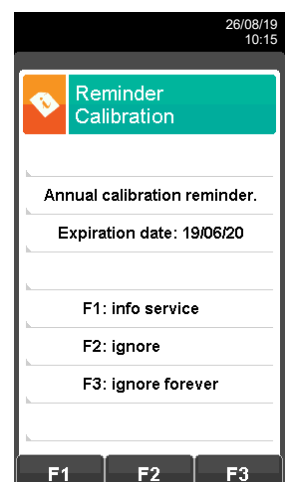
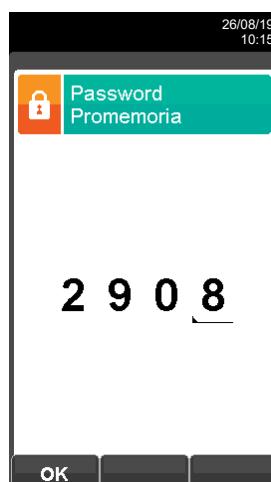
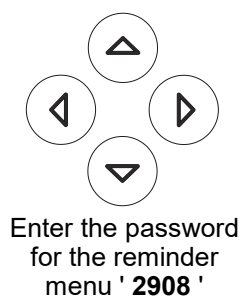
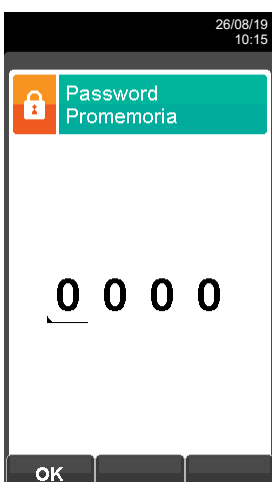

9.7 Configuration → Diagnostic

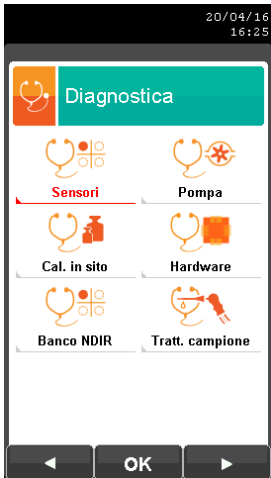

KEY	FUNCTION
	Activate the context keys shown on the display.
	Returns to the previous screen.

CONTEXT KEY	FUNCTION
	Selects the available parameters.
	Enters in the selected parameter setting.
	Selects the available parameters.

PARAMETER	DESCRIPTION
<p>Sensors</p>	<p>Displays information on the state and calibration of the electrochemical sensors:</p> <p>Ok No problem detected absent The sensor was not detected err data Sensor memory data error unknown It is necessary to update the FW of the device err pos The sensor has been installed in the wrong position err cal Calibration error (sensor not calibrated) err curr Currents outside the range err cfg Do not use this sensor as it has not been accepted on the screen "types of sensors".</p> <p>Also, from this screen the user can access the identification data of the sensor: type, serial number, date of manufacture and calibration. There are also the measured currents; in this way it is possible to perform a quick diagnosis in the event of a malfunction.</p> <p>SEE SECTION 9.8.</p>
<p>Pump</p>	<p>In this submenu it is possible to temporarily turn off the pump for smoke drawing or to switch it back. Furthermore, it is possible to visualize the actual pump flow expressed in liters per minute. It will not be possible to turn off the pump while the autozero cycle is being performed.</p> <p>SEE SECTION 9.9.</p>
<p>On site cal.</p>	<p>It is possible to make a recalibration of the instrument gas sensors with suitable known concentration gas cylinders. For the sensors sensible to other gases, called interfering gases (for example NH₃, H₂, H₂S, SO₂, ...) on-site calibration of the relevant interfering gases can also be performed.</p> <p>For factory calibration of the AACSE79 sensor, see chapter 16.7</p> <p>SEE SECTION 9.10.</p>
<p>Hardware</p>	<p>At instrument turn on the firmware performs a full check on the physical efficiency of all types of HW memories installed on the instrument, as well as on the integrity of the data stored into them. Any issue is displayed in the screen 'Memories Diagnostics'. Should this happen it is advisable to turn the instrument off and then on again. In case the problem is permanent or frequently recurring, the user should contact the Service Center reporting the error code shown by the instrument.</p> <p>SEE SECTION 9.11.</p>
<p>NDIR Bench</p>	<p>The user can check the status of the infrared bench NDIR.</p> <p>SEE SECTION 9.12.</p>
<p>Sample processing</p>	<p>Allows the user to check the status of the cooler (Peltier cells).</p> <p>SEE SECTION 9.13.</p>

9.8 Configuration → Diagnostic → Sensors

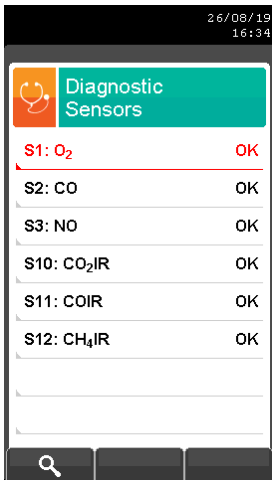
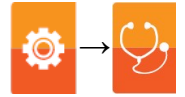

KEY	FUNCTION
	Activate the context keys shown on the display.
	Selects the fuel.
	Activates the context keys located in the left side of the display.
	Returns to the previous screen.

CONTEXT KEY	FUNCTION
	Displays the details of the selected sensor (see example below).
	Returns to the previous screen.

Example:

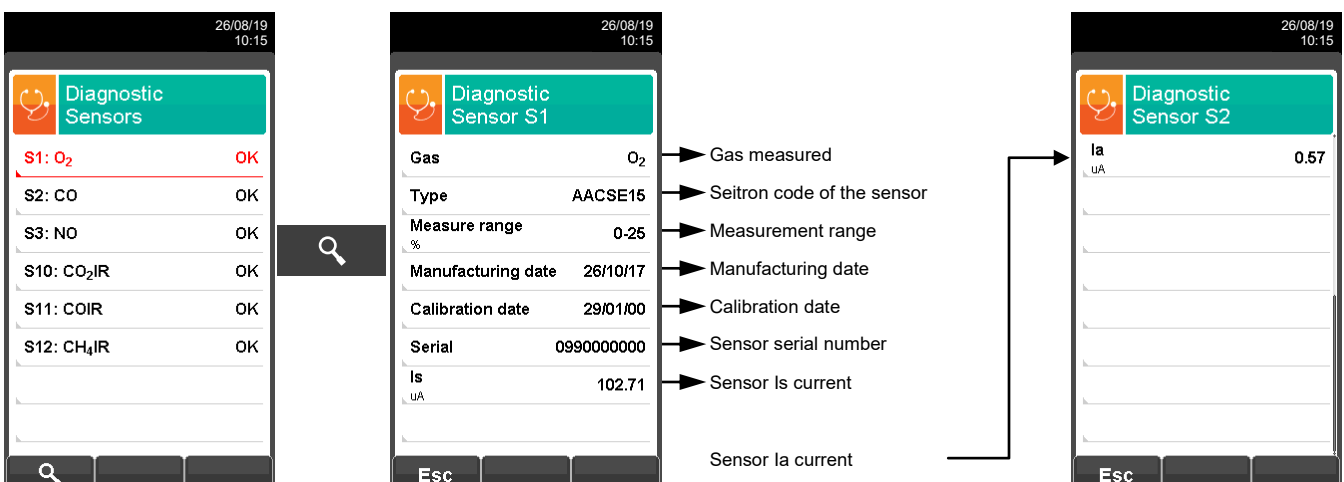

9.9 Configuration→Diagnostic→Pump

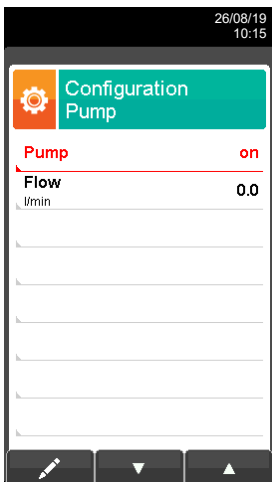
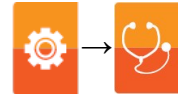

KEY	FUNCTION
	Activate the context keys shown on the display.
	When in edit mode, switches between on and off and vice versa.
	Enters the modify mode for the selected parameter, then confirms the modification.
	When pressed in modify mode cancels the selection made, otherwise returns to the previous screen.

CONTEXT KEY	FUNCTION
	Enters edit mode: it is possible to switch on / off the smoke drawing pump.
	Confirms the changes made.

9.10 On-site calibration procedure of electrochemical sensors and IR bench



On-site calibration of gas sensors applies a coefficient to the factory calibration in order to compensate for any current drift due to sensor wear over time.

This calibration will be carried out through the use of titrated gas cylinders.

All sensors have a factory calibration that will never be erased. In case the on-site calibration is not used, the instrument will automatically use the factory calibration.

General notes

1. The on-site calibration has to be performed inside the temperature range: $23\text{ }^{\circ}\text{C} \pm 3\text{ }^{\circ}\text{C}$ or $73\text{ }^{\circ}\text{F} \pm 5\text{ }^{\circ}\text{F}$
2. Leave the instrument at a temperature of $23\text{ }^{\circ}\text{C} \pm 3\text{ }^{\circ}\text{C}$ or $73\text{ }^{\circ}\text{F} \pm 5\text{ }^{\circ}\text{F}$ for at least 2 hours (thermal equilibrium)

The following tools and equipment are needed to perform recalibration:

- Known concentration gas mixture suitable for the sensor to be tested with known gas concentration; the gas bottle must be equipped with pressure regulator.
- Flowmeter
- Piping with 'T' branch for connecting the gas bottle to the instrument and flowmeter.

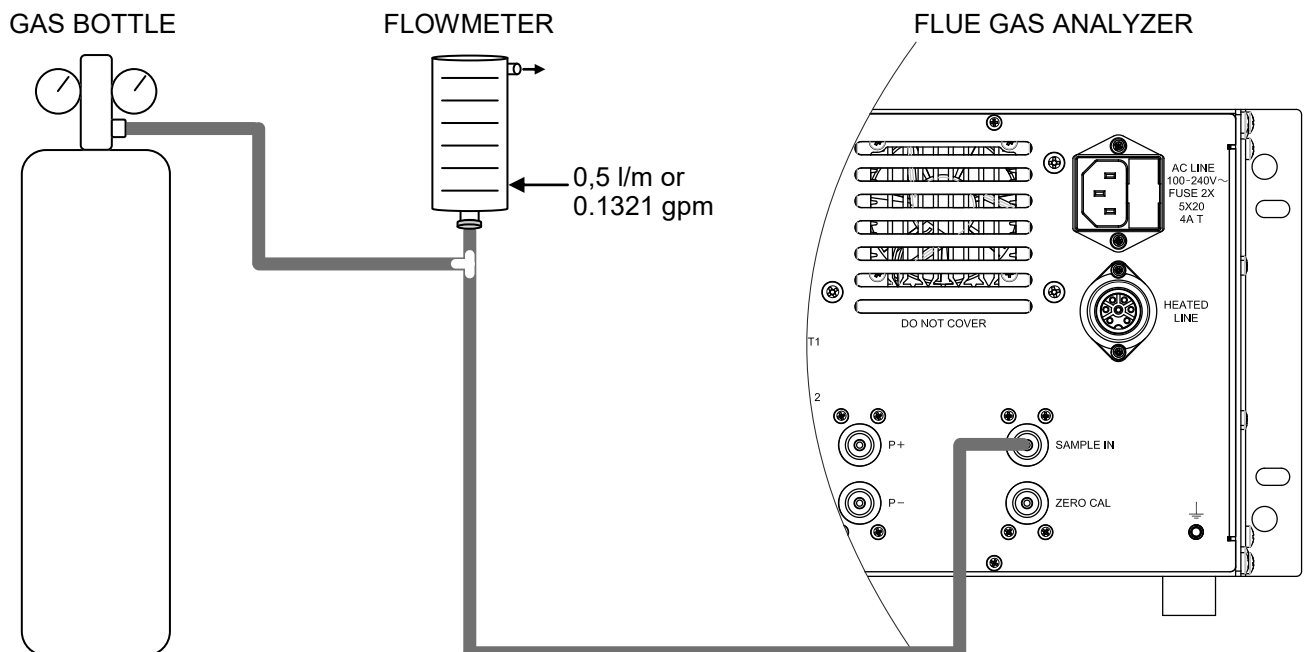

On site calibration procedure

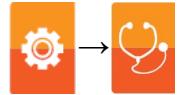

1. Turn on the instrument

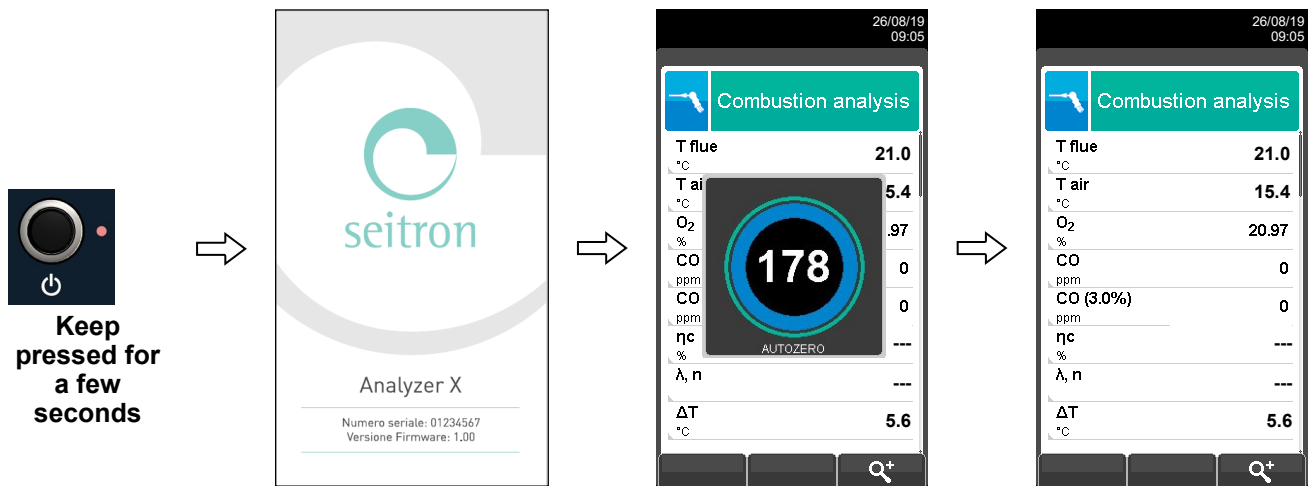

WARNING
Make sure that autozero runs in clean air and ends properly.

2. When the autozero is over press the key and select the icon “diagnostics”.

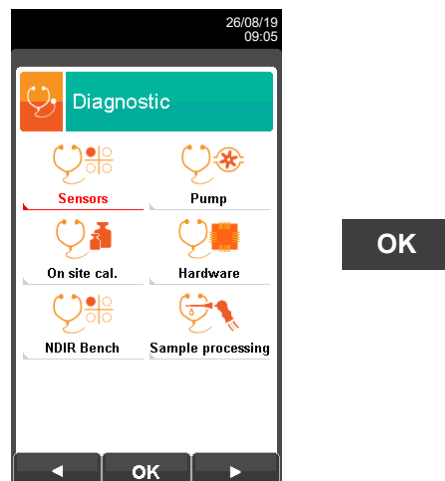

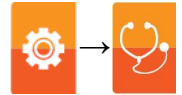

- Upon entering the on-site calibration menu, the list of installed sensors for which on-site recalibration can be performed is displayed.

When a sensor is selected, the recalibration screen displays all the information about the last calibration.

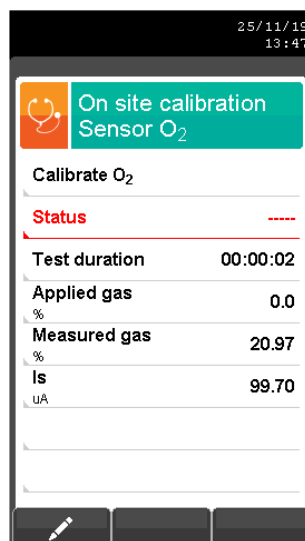
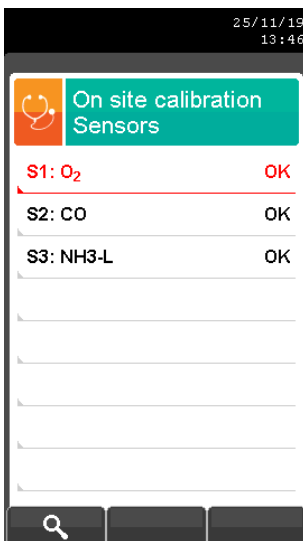

For the meaning of any errors present, see Chapter 9.8 Gas Sensor Diagnostics.

Calibrate:
Status: not active: saves a new calibration
 active: returns to factory calibration
 ----: returns to the last user calibration performed
 no on-site calibration performed

Duration: timer
Applied gas: enter applied gas concentration
Measured gas: measurement of applied gas concentration
Is: 'Is' current from sensor
la: 'la' current from sensor (only present in CO+H2 sensor calibration)

**Is and la currents are not present in the measurements for the IR bench (S10 - S11 - S12).
 la current is not present in some sensors (e.g., O₂); if this is not shown in the screen shots shown above, it means it is absent.**

CHOOSE THE SENSOR TO BE CALIBRATED AND DO AS FOLLOWS

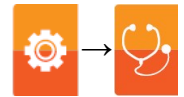

BLEND TO BE USED

- For the gas sensors on site calibration, Seitron recommends using known concentration gas mixtures defined in the table below.
- Alternatively, the gas concentration to be used can be defined by the operator based on the measuring point where the analyzer is normally working.
- For toxic gas sensors NH₃, SO₂, H₂S, H₂ also refer to the chapter "Calibration Detail of Toxic Gas Sensors with Interfering Gases."

The following table lists the sensors to be calibrated with data on the mixtures to be used.

SENSOR TO BE CALIBRATED: Sensor to be calibrated, selected in the "on-site sensor calibration" screen.

MIXTURE: Gas mixture to be used for on-site calibration of the selected sensor.

GAS CONCENTRATION: Gas concentration to be applied to the instrument for calibration.

GAS ACCURACY: Accuracy of gas concentration to be applied to the instrument.

The given data depends on the mixture manufacturer and its concentration.

COMPLEMENTARY GAS: Other gas contained in the mixture.

WAITING TIME: Having applied the gas to the instrument, it is necessary to wait for the indicated time useful to the gas to obtain a stabilization of the measurement.

NOTES: Any known directions on the gas to be used for on-site calibration of the sensor.

SENSOR TO CALIBRATE	MIXTURE			WAITING TIME	NOTES
	GAS CONCENTRATION	COMPLEMENTARY GAS	GAS ACCURACY		
O ₂ (0-100%Vol.) Cod.AASE81R	O ₂ 0,0% Vol.	n.a.	n.a.	60 sec.	Use N ₂ or bottles with toxic gas balance in N ₂
O ₂ (0-20,9%Vol.) Cod.AASE15R	O ₂ 0,0% Vol.	n.a.	n.a.	60 sec.	Use N ₂ or bottles with toxic gas balance in N ₂
O ₂ (0-20,9% Vol.) Cod. ACSE44 Long Life	O ₂ 0,0% Vol.	n.a.	n.a.	60 sec.	Use N ₂ or bottles with toxic gas balance in N ₂
CO+H ₂ compensated (0-8000ppm) Cod. AACSE12	CO 1000 ppm	Air	1% / 2% Depends on the mixture supplier	180 sec.	
CO+H ₂ low sensitivity (0-8000 ppm) Cod. AACSE20	CO 1000 ppm	Air	1% / 2% Depends on the mixture supplier	180 sec.	
CO+H ₂ compensated (0-500,0 ppm) Cod. AACSE24	CO 200 ppm	Air	1% / 2% Depends on the mixture supplier	180 sec.	
CO (0-20000 ppm) Cod. AACSE18	CO 8000 ppm	Air	1% / 2% Depends on the mixture supplier	180 sec.	
CO (0-100000 ppm) (10,00%) Cod. AACSE17	CO 50000 ppm	Air	1% / 2% Depends on the mixture supplier	180 sec.	
NO _x (0-5000 ppm) Cod. AACSE10	NO 800 ppm or 1000 ppm	Nitrogen	1% / 2% Depends on the mixture supplier	180 sec.	

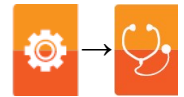

SENSOR TO CALIBRATE	MIXTURE			WAITING TIME	NOTES
	GAS CONCENTRATION	COMPLEMENTARY GAS	GAS ACCURACY		
NO _x (0-500,0 ppm) Cod. AACSE25	NO 200 ppm	Nitrogen	1% / 2% Depends on the mixture supplier	180 sec.	
NO ₂ (0-1000 ppm) Cod. AACSE14	NO ₂ 120 ppm	Nitrogen	1% / 2% Depends on the mixture supplier	180 sec.	
NO ₂ (0-500,0 ppm) Cod. AACSE26	NO ₂ 80 ppm	Nitrogen	1% / 2% Depends on the mixture supplier	180 sec.	
C _x H _y (0-50000 ppm) (5,00% Vol.) Cod. AACSE23	CH ₄ 22000 ppm	Air	1% / 2% Depends on the mixture supplier	180 sec.	
C _x H _y (0-50000 ppm) (5,00% Vol.) Cod. AACSE39	CH ₄ 22000 ppm	Air	1% / 2% Depends on the mixture supplier	180 sec.	
SO ₂ (0-5000 ppm) Cod. AACSE13	SO ₂ 1000 ppm	Nitrogen	1% / 2% Depends on the mixture supplier	180 sec.	
	For interfering gas CO CO 1000 ppm	Air	1% / 2% Depends on the mixture supplier	180 sec.	
	For interfering gas NO_x NO _x 800 ppm or 1000 ppm	Nitrogen	1% / 2% Depends on the mixture supplier	180 sec.	
	For interfering gas NO₂ NO ₂ 120 ppm	Nitrogen	1% / 2% Depends on the mixture supplier	180 sec.	
SO ₂ (0-500,0 ppm) Cod. AACSE28	SO ₂ 220 ppm	Nitrogen	1% / 2% Depends on the mixture supplier	180 sec.	
	For interfering gas CO CO 150 ppm or 200 ppm	Air	1% / 2% Depends on the mixture supplier	180 sec.	
	For interfering gas NO_x 200 ppm	Nitrogen	1% / 2% Depends on the mixture supplier	180 sec.	
	For interfering gas NO₂ 120 ppm	Nitrogen	1% / 2% Depends on the mixture supplier	180 sec.	
CO ₂ (0-100% Vol.) Cod. AACSE47	CO ₂	Air	1% / 2% Depends on the mixture supplier	180 sec.	

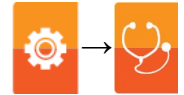

SENSOR TO CALIBRATE	MIXTURE			WAITING TIME	NOTES
	GAS CONCENTRATION	COMPLEMENTARY GAS	GAS ACCURACY		
H2S (0-500,0 ppm) Cod. AACSE35	H2S 200 ppm	Nitrogen	1% / 2% Depends on the mixture supplier	180 sec.	
	For interfering gas SO2 200 ppm	Air	1% / 2% Depends on the mixture supplier	180 sec.	
	For interfering gas NOx 200 ppm	Nitrogen	1% / 2% Depends on the mixture supplier	180 sec.	
	For interfering gas NO2 120 ppm	Nitrogen	1% / 2% Depends on the mixture supplier	180 sec.	
NH3 (0-500,0 ppm) Cod. AACSE56	NH3 200 ppm	Nitrogen	1% / 2% Depends on the mixture supplier	180 sec.	
	For interfering gas H2S 20 ppm	Air	1% / 2% Depends on the mixture supplier	180 sec.	
	For interfering gas SO2 200 ppm	Nitrogen	1% / 2% Depends on the mixture supplier	180 sec.	
	For interfering gas NO 200 ppm	Nitrogen	1% / 2% Depends on the mixture supplier	180 sec.	
H2S (0-5000 ppm) Cod. AACSE72	H2S 200 ppm	Nitrogen	1% / 2% Depends on the mixture supplier	180 sec.	
	For interfering gas SO2 200 ppm	Air	1% / 2% Depends on the mixture supplier	180 sec.	
	For interfering gas NOx 200 ppm	Nitrogen	1% / 2% Depends on the mixture supplier	180 sec.	
	For interfering gas NO2 120 ppm	Nitrogen	1% / 2% Depends on the mixture supplier	180 sec.	
SO2 (J57-2017) (0-5000 ppm) Cod. AACSE77	So2 200 ppm	Nitrogen	1% / 2% Depends on the mixture supplier	300 sec.	
	For interfering gas CO Not required	n.a.	n.a.	n.a.	
	For interfering gas NOx 200 ppm	Nitrogen	1% / 2% Depends on the mixture supplier	180 sec.	
	For interfering gas NO2 120 ppm	Nitrogen	1% / 2% Depends on the mixture supplier	300 sec.	

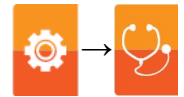

SENSOR TO CALIBRATE	MIXTURE			WAITING TIME	NOTES
	GAS CONCENTRATION	COMPLEMENTARY GAS	GAS ACCURACY		
H2 (0-40000 ppm) Cod. AACSE78	H2 20000 ppm	Air	1% / 2% Depends on the mixture supplier	240 sec.	
	For interfering gas CO 1000 ppm	Air	1% / 2% Depends on the mixture supplier	180 sec.	
	For interfering gas NO2 120 ppm	Nitrogen	1% / 2% Depends on the mixture supplier	180 sec.	
	For interfering gas NO 800 ppm	Nitrogen	1% / 2% Depends on the mixture supplier	180 sec.	
DUAL CO (0-8000 ppm) H2 (0-2000 ppm) Cod. AACSE79	CO 1000 ppm	Air	1% / 2% Depends on the supplier of the mixture	180 sec.	
	H2 H2 800 ppm	Air	1% / 2% Depends on the supplier of the mixture	240 sec.	
CO2 IR (0-50,00%Vol.) Cod. AACSE38 (NDIR Bench)	CO2 18,00 % Vol	Air	1% / 2% Depends on the mixture supplier	180 sec.	
CO IR (0-50,00% Vol.) Cod. AACSE38 (NDIR Bench)	CO 8000 ppm	Air	1% / 2% Depends on the mixture supplier	180 sec.	
CH4 (0-1000000 ppm) Cod. AACSE38 (NDIR Bench)	CH4 22000 ppm	Air	1% / 2% Depends on the mixture supplier	180 sec.	
CO2 IR (0-50,00%Vol.) Cod. AACSE76 (NDIR Bench)	CO2 18,00 % Vol	Air	1% / 2% Depends on the mixture supplier	180 sec.	
CO IR (0-50,00% Vol.) Cod. AACSE76 (NDIR Bench)	CO 8000 ppm	Air	1% / 2% Depends on the mixture supplier	180 sec.	
HC (0-1000000 ppm) Cod. AACSE76 (ND—IR Bench)	CH4 22000 ppm	Air	1% / 2%	180 sec.	

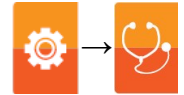

WARNING!

SAFETY INSTRUCTIONS FOR AACSE80 BENCH CALIBRATION

SENSOR TO CALIBRATE	MIXTURE			WAITING TIME	NOTES
	GAS CONCENTRATION	COMPLEMENTARY GAS	GAS ACCURACY		
CO2 IR (0-50,00%Vol.) Cod. AACSE80 (NDIR Bench)	CO ₂ 0,45% Vol.	Nitrogen	1% / 2% Depends on the mixture supplier	180 sec.	Use N ₂ or bottles with toxic gas balance in N ₂
CO2 IR (0-50,00%Vol.) Cod. AACSE80 (NDIR Bench)	O ₂ 36% Vol.	Nitrogen	1% / 2% Depends on the mixture supplier	180 sec.	Use N ₂ or bottles with toxic gas balance in N ₂
CO2 IR (0-50,00%Vol.) Cod. AACSE80 (NDIR Bench)	CH ₄ 9% Vol.	Nitrogen	1% / 2% Depends on the mixture supplier	180 sec.	

WARNING!

- THE GAS TO BE USED FOR CALIBRATION OF THE AACSE80 INFRARED BENCH SHOULD BE CONTAINED IN A SINGLE MIXTURE IN THE CONCENTRATION GIVEN IN THE TABLE ABOVE.
- THE AACSE80 INFRARED BENCH CALIBRATION MUST BE PERFORMED BY PERSONNEL TRAINED USING DEADLY GAS CONCENTRATION.

NOTES: DURING CALIBRATION, SET THE COEFFICIENT OF H₂ TO 24.
AFTER CALIBRATION, RESET TO THE VALUE PREVIOUSLY SET BY THE CUSTOMER.
THE VALUE CAN BE FOUND IN THE NDIR BENCH CONFIGURATION MENU.

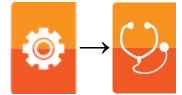

PROCEDURE

- The calibration will be possible only when the status is set to '----' (sensors which never had an on-site calibration) or it is necessary to set the state to 'not active' (see example).

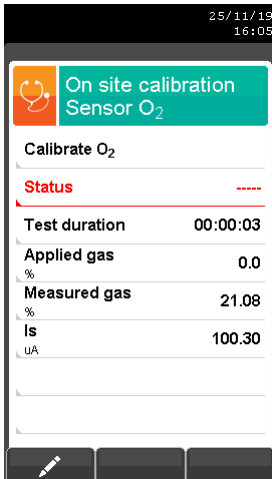

OR

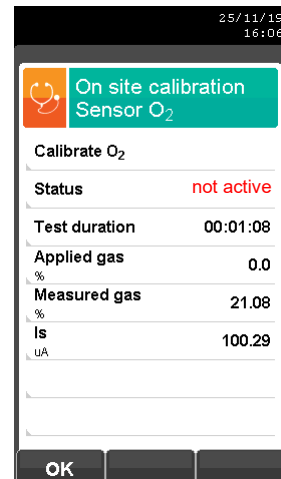
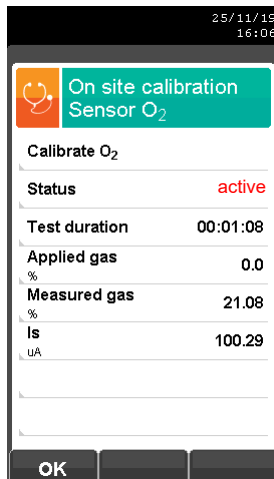
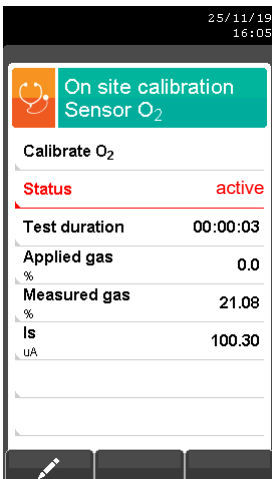

- Enter the concentration value of the applied gas

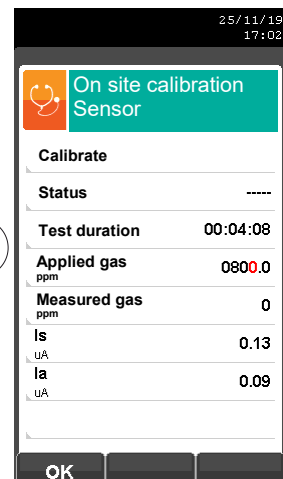
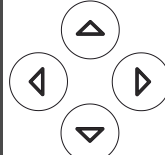
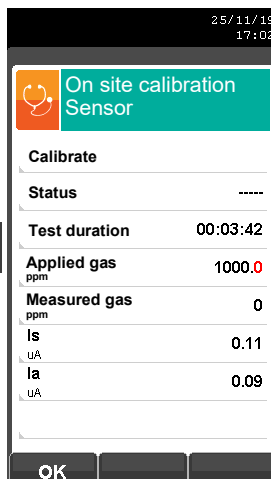
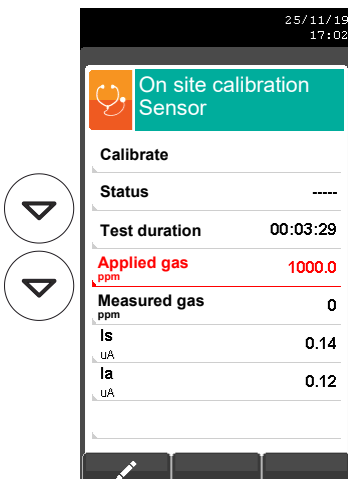

- Apply gas to the instrument and adjust the gas outlet pressure from the bottle so that the flowmeter indicates a minimum flow of 0.5 l/m or 0.13 gpm: this ensures that the instrument is drawing exactly the required amount of gas through the internal pump.

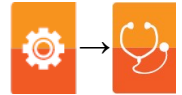

- The instrument measures the concentration of the applied gas; wait at least 3 minutes for the reading to stabilize. The reading is shown at the 'Measured gas' line.

Zeroes the timer - helps to keep under control the time elapsing during the stabilization phase.

- When the stabilization time is over, select the 'Calibration' row and store the new calibration.

Once the new calibration has been stored, the possible temporary messages which can be seen on the row 'status' are the following:

- saving:** the instrument is saving the performed calibration
- error:** the sensor has NOT been recalibrated for any of the following reasons:
 - The calibration gas cannot properly reach the instrument.
 - Concentration for the calibration gas has not been set in the relevant line 'Applied gas'.
 - The user didn't allow for the stabilization time to properly elapse.
 - The sensor could be damaged or exhausted and must therefore be replaced.

WARNING

- It is always possible to return the instrument to factory calibration by setting the 'Status' line to 'inactive'.
- The recommended stabilization time for sensors on-site calibration is 3 minutes. For NO₂ and SO₂ sensors, this time can be up to 5 minutes.

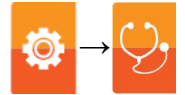

Detailed calibration of toxic gas sensors with interfering gases

The toxic gases sensors with interfering gases are these sensors sensible to other gases. The on site calibration for these sensors also allows to calibrate the interfering gases.

Toxic gas sensor table with interfering gases

SENSOR	INTERFERING GASES		
NH ₃	H ₂ S	SO ₂	NO
SO ₂	CO	NO	NO ₂
H ₂ S	SO ₂	NO	NO ₂
H ₂	CO	NO	NO ₂

The on site calibration procedure for these sensors is the same described in the previous pages regarding the toxic gases sensors and it can be performed for all the gases which interferes with the sensor itself.

On the following is described the mode to access the interfering gases with the sensor which must be calibrated on site (example referred to NH₃ sensor).

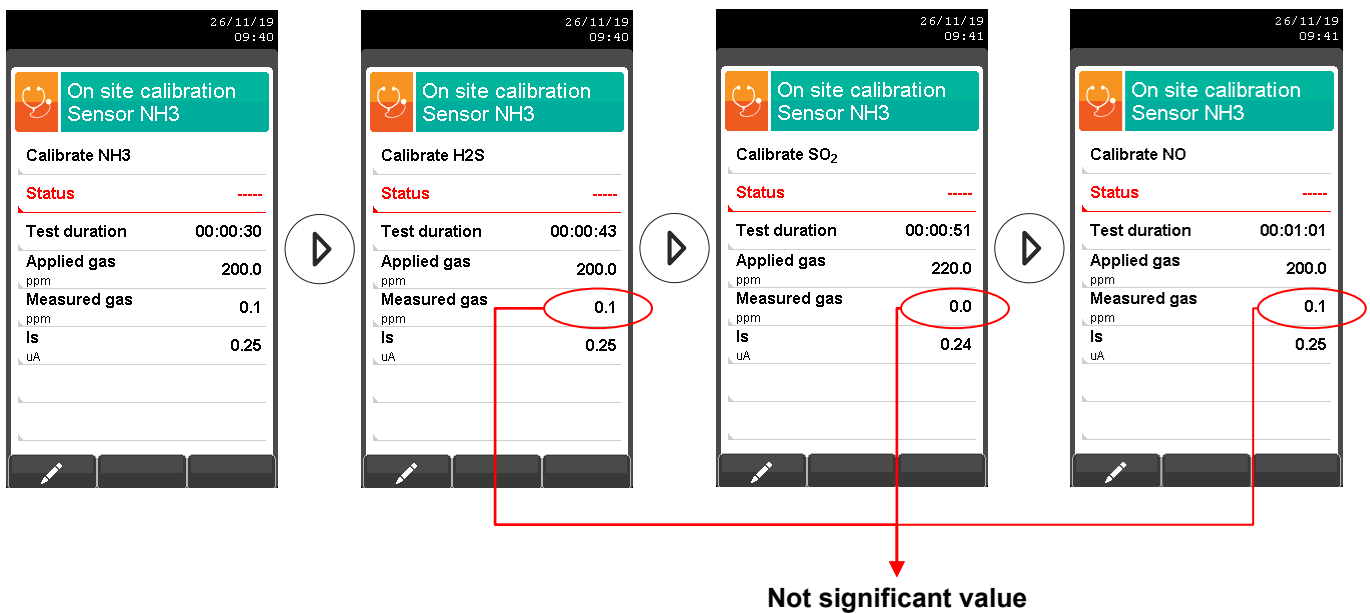

9.11 Configuration → Diagnostic → Hardware

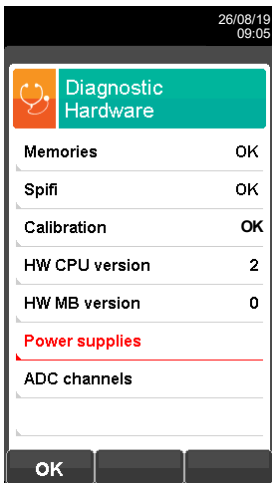
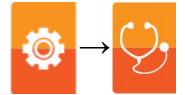

- State of memory
- State of flash memory
- State of calibration
- Version of CPU board
- Version of motherboard
- Main power supplies
- ADC converter input signals

KEY	FUNCTION
	Activate the context keys shown on the display.
	Returns to the previous screen.

CONTEXT KEY	FUNCTION
	Returns to the previous screen.
	Shows values in mV
	Shows values in bits

9.12 Configuration → Diagnostic → NDIR bench

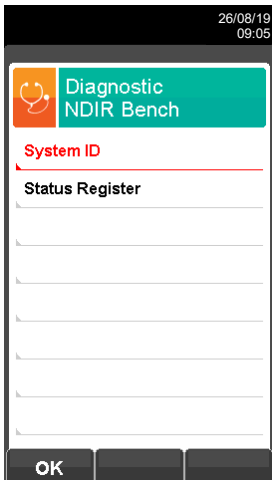

→ NDIR bench identification data.
 → NDIR bench information about operational status.

KEY	FUNCTION
	Activate the context keys shown on the display.
	Selects line; the selected line is displayed in red.
	Activates the context key located in the left side of the display.
	Returns to the previous screen.

CONTEXT KEY	FUNCTION
	Enters in the selected data setting.
	Returns to the previous screen.

9.13 Configuration → Diagnostic → Sample processing

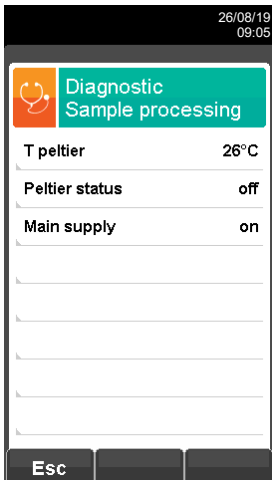
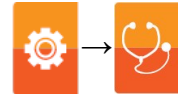

KEY	FUNCTION
	Activate the context keys shown on the display.
	Returns to the previous screen.

CONTEXT KEY	FUNCTION
	Returns to the previous screen.

9.14 Configuration→Language



KEY	FUNCTION
	Activate the context keys shown on the display.
	Scrolls through the available languages.
	Sets the selected language.
	Returns to the previous screen.

CONTEXT KEY	FUNCTION
	Sets the selected language.



9.15 Configuration→Restore

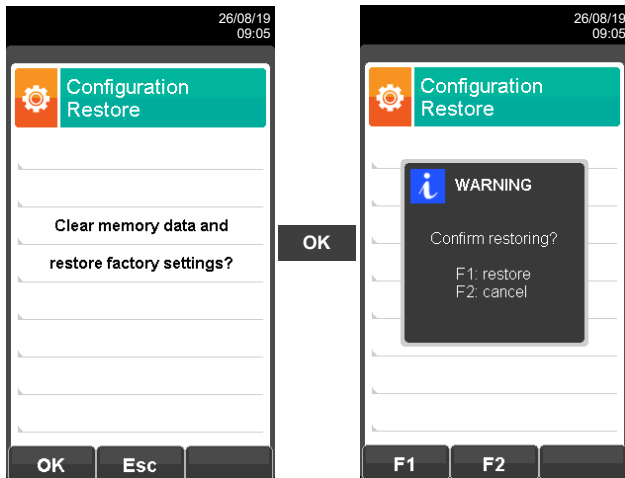

KEY	FUNCTION
	Activate the context keys shown on the display.
	Starts the factory values reset phase.
	Exits the current screen without resetting to factory values.

CONTEXT KEY	FUNCTION
	Starts the factory data reset phase.
	Exits the current screen without resetting.
	Factory reset.
	Cancels the factory data reset phase and goes back to the previous screen.

10.1 Measurements Menu

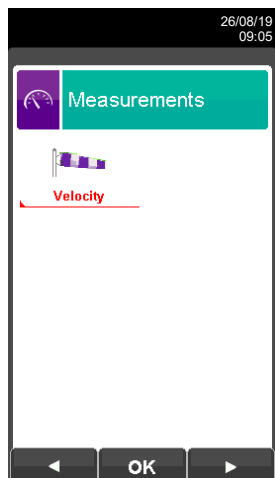

KEY	FUNCTION
	Activate the context keys shown on the display.
	Returns to the previous screen.

CONTEXT KEY	FUNCTION
	Selects the available parameters.
	Enters in the selected parameter setting.
	Selects the available parameters.

PARAMETER	DESCRIPTION
 Velocity	When a Pitot tube and a Tc-K thermocouple are connected, the instrument is capable to measure at the same time both temperature and velocity of a gas (air/flue gas). SEE SECTION 10.1.2.



10.1.2 Measurements → Velocity

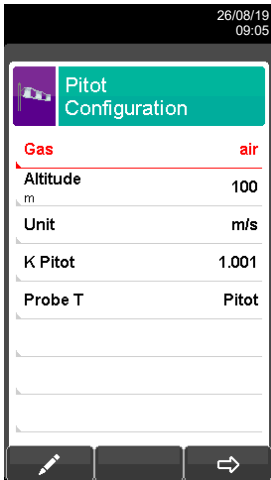

- Measurement: air or flue gas.
- Altitude above sea level.
- Measurement unit selectable across m/s, km/h, fpm, mph.
- Insert the K-factor of the Pitot tube stated by the tube manufacturer.
- Temperature acquisition mode:
Pitot (with Tc-K thermocouple) or Flue gas probe (or external Tc-K thermocouple).

KEY	FUNCTION
	Activate the context keys shown on the display.
	Selects line; the selected line is displayed in red. In edit mode, it sets the desired value.
	Activates the context key located in the left side of the display.
	Returns to the previous screen. When in modify mode cancels the modification just made.

CONTEXT KEY	FUNCTION
	Enters the modification mode for the selected parameter.
	Confirms the entered value.
	Go to next step.
	Make the zero for the measurement.
	Saves, in the memory selected in the "Select Memory" menu, the acquired data.

11.1 PRELIMINARY OPERATIONS

Before starting the emission analysis, follow the instructions in the following points.



- By pressing the On/Off key or as soon as it is powered up, the instrument starts displaying the presentation screen. After a few moments, the instrument automatically proceeds to the autozero phase. It is important that this phase is performed in an environment with clean air. During autozero, a temperature-compensated zero of the piezoresistive pressure sensor is also performed.
- At the time the instrument is turned on, the main pump is not on but only the condensate drain pump is on for the time set in the parameter **Settings->Configuration->Instrument->Pumps->Peristaltic**. This is to prevent any water that may be present in the cooler when the instrument is turned on from preventing the main pump from drawing in the flue gases properly. After this time, the main pump will turn on normally.

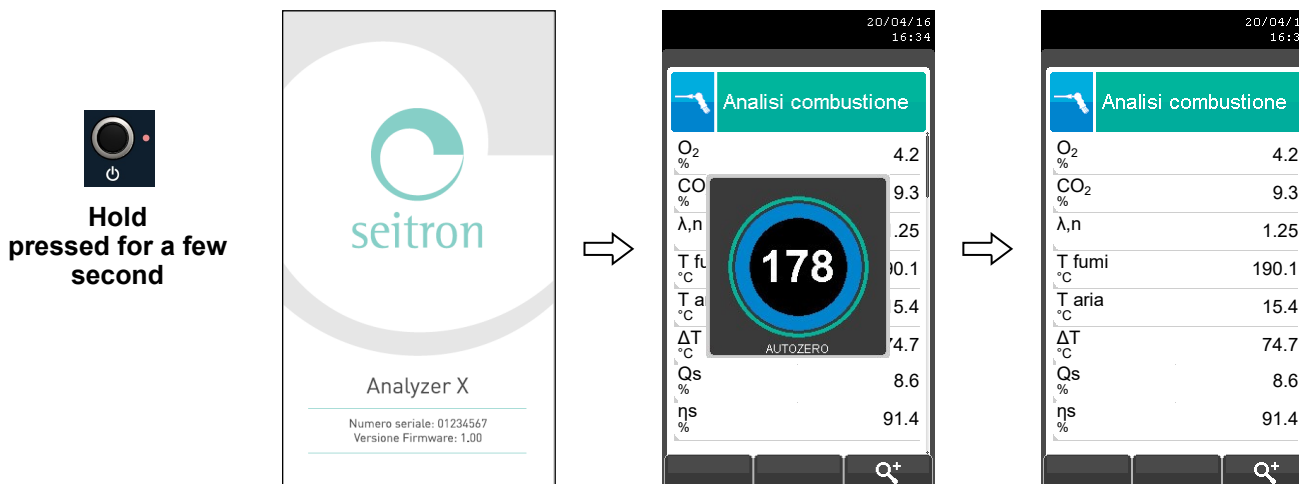

- Then the instrument automatically proceeds with the flue gas analysis according with the configuration made.



SOME IMPORTANT WARNINGS ARE LISTED BELOW:

IN ORDER TO GET A CORRECT ANALYSIS IT IS NECESSARY THAT NO EXTERNAL AIR ENTERS THE DUCT BECAUSE OF A BAD LOCKING OF THE CONE OR BECAUSE OF LEAKAGE ON THE PIPING.

THE SMOKE TUBE MUST BE VERIFIED TO AVOID THE PRESENCE OF LEAKAGES OR OBSTRUCTIONS ALONG THE PATH.

THE CONNECTORS OF THE SMOKE PROBE MUST BE TIGHTLY LOCKED TO THE INSTRUMENT.

DO NOT PERFORM MEASURES WITHOUT A FILTER OR WITH A DIRTY FILTER TO AVOID AN IRREVERSIBLE DAMEGE TO THE SENSORS.

IN ANALYSIS MODE, THE HEATED LINE (IF ENABLED) IS ALWAYS ON.

THE ACTIVATION OF THE HEATED LINE STARTS 20 MINUTES BEFORE THE STARTING OF THE ANALYSIS.

BEFORE CONNECTING THE USB CABLE, WAIT FOR THE AUTOZERO OF THE INSTRUMENT TO BE OVER.

ADD TO THE MEASUREMENT LIST ANY ADDITIONAL MEASURES WHICH ARE NEEDED TO BE PERFORMED.

THE SHOWN DATA ABOUT THE POLLUTING ELEMENTS CO / NO / NO_x CAN BE TRANSLATED IN NORMALIZED VALUES (REFERRING TO THE CONCENTRATION OF O₂ PREVIOUSLY SET).

THE FLUE GAS PUMP IS TURNED OFF FOR THE FIRST 30 SECONDS AFTER TURNING ON TO ALLOW THE PERISTALTIC PUMP TO CLEAR CONDENSATE.

11.2 EMISSION ANALYSIS CONFIGURATION MODE

Before Before using the combustion analyzer, it's crucial to properly configure the analysis mode. Connect the device to a PC via USB and install the "Seitron smart analysis" software available at www.seitronamericas.com.

This allows for complete customization for monitoring emissions, with options to start the analysis immediately or schedule it for a specific time.

The device automatically collects samples according to the settings and enables real-time monitoring of the process. Results can be displayed directly on the device or transferred to a PC for further analysis. In the main screen of the "Seitron smart analysis" software, you can configure the analysis parameters in detail.



11.2.1 ANALYSIS ACQUISITION MODE SET TO "PC DATA LOGGER".

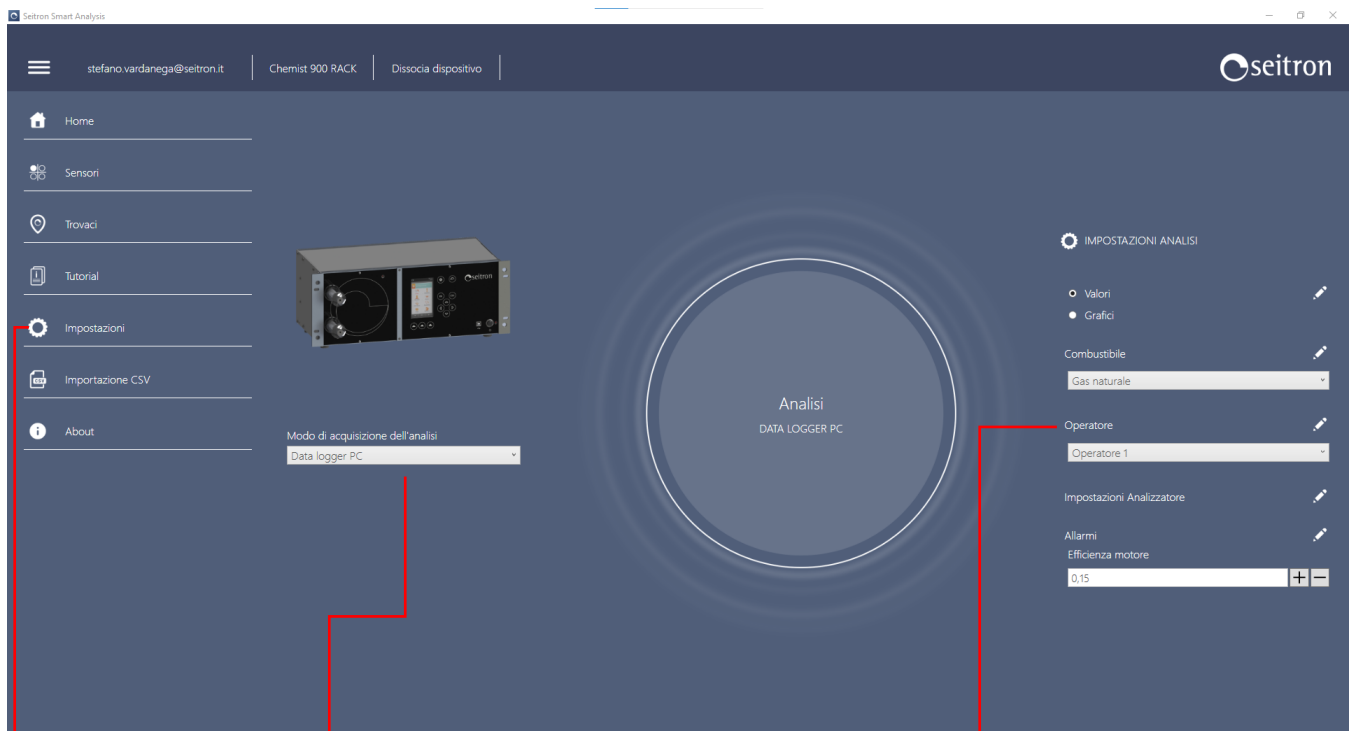

ANALYSIS ACQUISITION MODE

In this menu it is possible to define the analysis mode used by the instrument to monitor the polluting emissions.

It is possible to choose between:

- Data logger PC**
- Periodic**

SETTINGS

Advanced settings based on the set analysis acquisition.

For further details see the following pages.

ANALYSIS SETTINGS

Whatever the set analysis mode is, it is necessary to properly set this menu:

Values / Graphs

By clicking on “” it is possible to visualize the list of the measures that the instrument is performing (available measures) and the list of the measures shown when the analysis is being performed (measures to be shown).

Moreover it is possible to add, delete or move by one position a selected measure.

Fuel

It allows the choice of the fuel to be used when the analysis is being performed. By clicking on “” it is possible to visualize the coefficients of the fuels used for calculating combustion efficiency and add a new fuel.

Operator

Allows the choice of the operator performing the analysis. The settable data depend on the selected analysis mode. By clicking on “” it is possible to insert or modify the operator’s name.

Analyzer settings

This parameter allows to manage the analyzer. The settable data depend on the selected analysis mode.

By clicking on “” it is possible to configure the instrument. See the following for further details.

Alarms

Click “” to configure and store 10 alarms. [See section 9.1 Configuration menu for more details.](#)

Motor efficiency

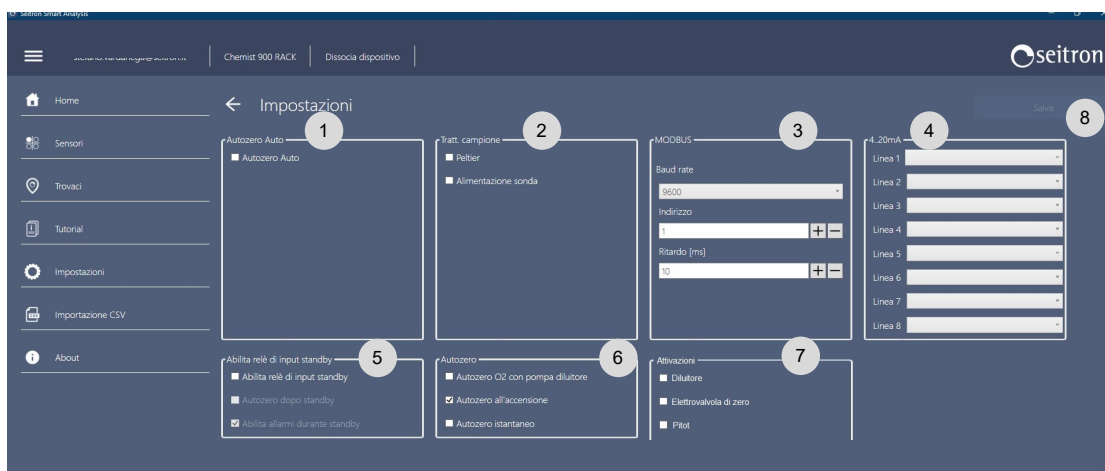

- 1 Enabling automatic autozero: the instrument is capable of performing automatic autozero after a preset time interval has elapsed, which can be set by the user in a value between 10 and 9999 minutes.

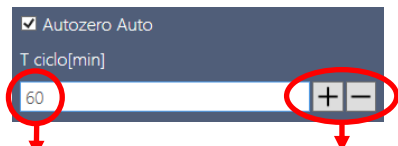

Interval between one cycle of autozero and another.

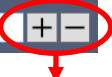

Increases or decreases the time interval between autozero cycles.
- 2 If these flags are enabled, the instrument turns on the Cooler and/or the heated tube. Conversely, if they are disabled, the instrument keeps the Cooler and/or the heated tube turned off. The heated tube can be set to reach a temperature between 90 and 130 °C.
- 3 Set the parameters for the MODBUS connection between the tool and an external PC/PLC. See chapter 9.3.9 for further information. Also, refer to the MODBUS specifications of the PC/PLC in use.
- 4 Activate the respective 4 ... 20 mA output line with the analysis parameter chosen from the dropdown menu. For further details, refer to chapter 9.3.5.
- 5 Additional analyzer settings:
 - Enable the possibility to put the tool on standby via a contact between the analog output 34 and 20 of the 37-pin vertical connector.
 - Enable the possibility that at the end of standby, an autozero cycle is performed.
 - During the standby phase, it is possible to decide whether any activated alarms should be ignored or not; for example, if an alarm concerns the flow rate of the main pump and during the standby phase it turns off, the flow rate will drop to zero triggering the alarm. This alarm can be ignored by the instrument by activating this option.
- 6 Autozero settings:
 - By activating the "**Autozero O2 with dilution pump**" option, it is possible to perform oxygen autozero with air and simultaneously perform autozero of all other gases in nitrogen. To achieve this function, it is necessary for the oxygen sensor to be installed in position **S2**. It is possible to move the **CO** sensor, if present, to position **S2** and place the oxygen sensor in its place. See the instrument maintenance manual for details on sensor positioning.
 - By enabling the "**Autozero on startup**" option, the instrument does not perform autozero automatically upon the next restart. Instead, a pop-up will appear prompting the user to press the F1 key to manually perform autozero. Until the user presses the F1 key, the tool will remain in a locked state.
 - By enabling the "**Instant Autozero**" option, the instrument ignores the autozero time interval previously set and performs a very brief autozero, skipping the wait time to perform the full autozero. This option is useful when clean air is immediately available. The waiting time can last up to 30 sec (check the actual duration on the pop up).

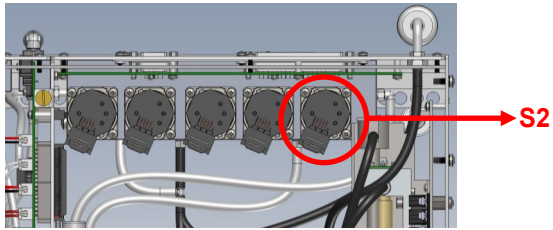
- 7 Activations:
 - '**Diluitore**': Enables or disables the diluter, if present in the instrument configuration.
 - '**Autozero solenoid valve**': Enables or disables the zero solenoid valve, if present in the instrument configuration. This option is useful in the laboratory when using one line for gas analysis and autozero must be performed with clean air. The system upstream of the gas inlet of the instrument will provide the gas to be analyzed or clean air.
 - '**Pitot**': Enables or disables Pitot tube measurement, if present in the instrument configuration.
- 8 Once the changes have been made, press the 'Save' button.



Settings

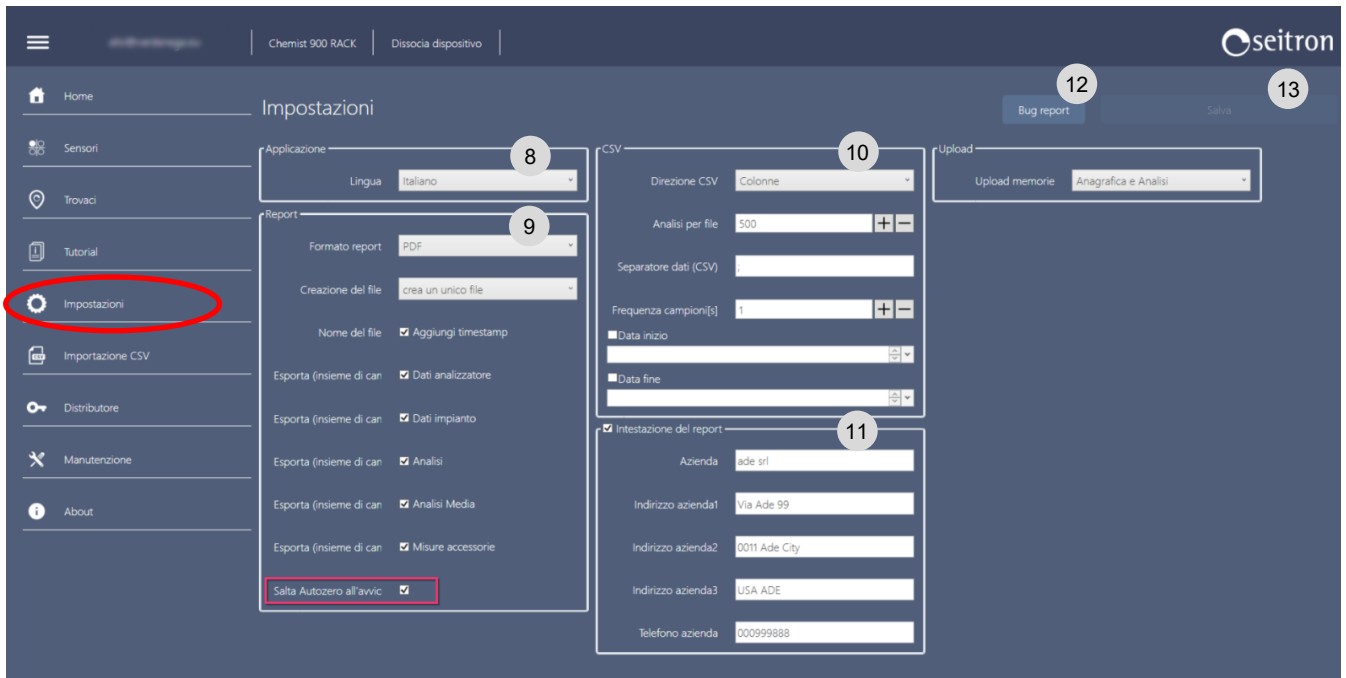

- 8 Set the language of the software interface.
- 9 Allows various features of the analysis report to be set, including file format (PDF, xml or csv), creation of a single file for each analysis, etc.
WARNING. If you choose "Skip Autozero at startup," the instrument will use the data from the last available autozero and will NOT perform the autozero on restart. For this reason, it is recommended to perform an autozero at first power-up and then connect the instrument to the PC software. You can still manually run an autozero by pressing "Start Autozero" on the main analysis measurements page if necessary.
- 10 Setting up csv files (with separator ;).
- 11 Data compilation for report header.
- 12 This button generates a compressed archive with a set of analyzer-related event logs. If a bug is found please attach that folder to your report so that technicians can more accurately reconstruct the problem.
- 13 Once the required changes have been made, for them to take effect, press the 'Save' button.

Sensors



- 14 In the sensors tab of the PC software, the measurement of one or more sensors can be turned on or off by checking or unchecking the relevant checkboxes. This allows the user to isolate required measurements from possible interfering factors, ensuring accurate readings. E.g., in a laboratory making measurements of individual gases, it is advisable to activate only the sensor of the gas being analyzed, excluding the others. Repeating this process for each gas results in a measurement free of specific interferences.



11.2.2 ANALYSIS ACQUISITION MODE SET TO "PERIODIC"

This mode, which is entirely user-configurable, allows pollutant emissions to be monitored at defined time intervals. The start of emission analysis is user-defined (immediate or programmed by day and time). When emission analysis begins, the instrument will automatically proceed to acquire the set number of samples. During the acquisition, you can follow its progress.

CAUTION.

THE INSTRUMENT AUTOZERO IS PERFORMED AT THE BEGINNING OF EACH ANALYSIS CYCLE. AT THE END OF EACH ANALYSIS CYCLE, THE ANALYZER WILL PERFORM CELL AND PNEUMATIC CIRCUIT CLEANING; THE DURATION IS DEFINED BY THE USER.

The specific data to be set, can be found within the "Settings" menu and by clicking on the "✎" symbol:

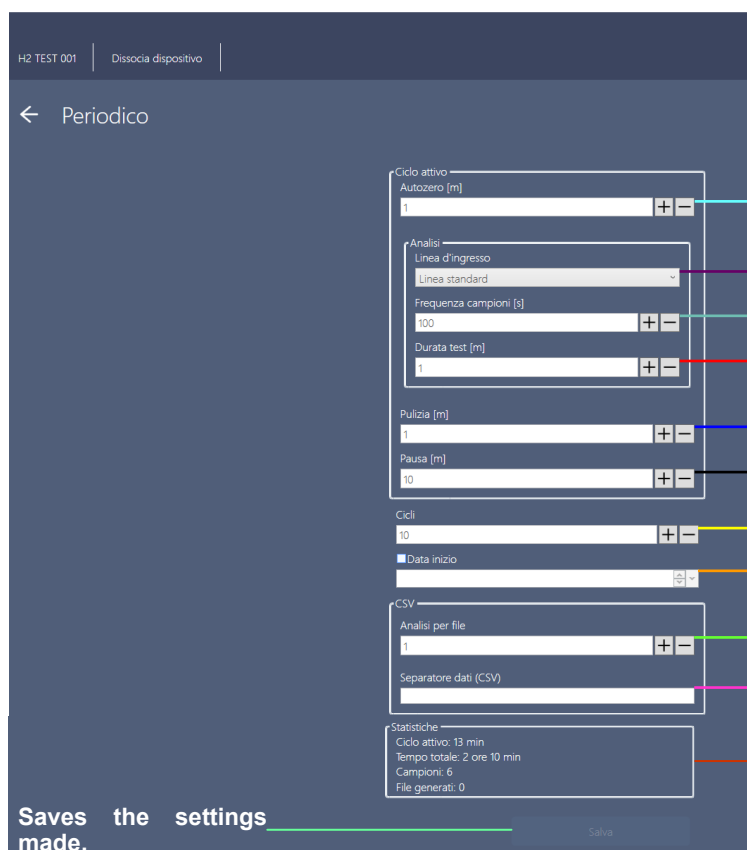

A Duration of autozero, which will be performed at the beginning of each analysis cycle.

This parameter is to be configured if you wish to take flue gas from two different points using two flue gas sampling lines that will be controlled by relay outputs 3 and 4. See section 9.2.8 for more details.

B Time between one sample and the next.

F Duration of analysis (expressed in minutes).

C Duration of cleaning, which will be carried out at the end of each analysis cycle.

D Time (expressed in minutes) in which the instrument turns off the fume suction pump and does not perform any analysis.

E Number of times you want to repeat cycle acquisition.

Date and time of start of emission analysis.

Number of samples contained in a .csv file.

Data separator character in .csv file.

Summary of settings made:
 Active cycle: Duration of a cycle
 Total time: Total duration of the analysis
 Samples: Number of samples that will be run
 Files generated: Number of .csv files that will be saved in the PC



Functioning logic of the “Periodic” analysis mode.

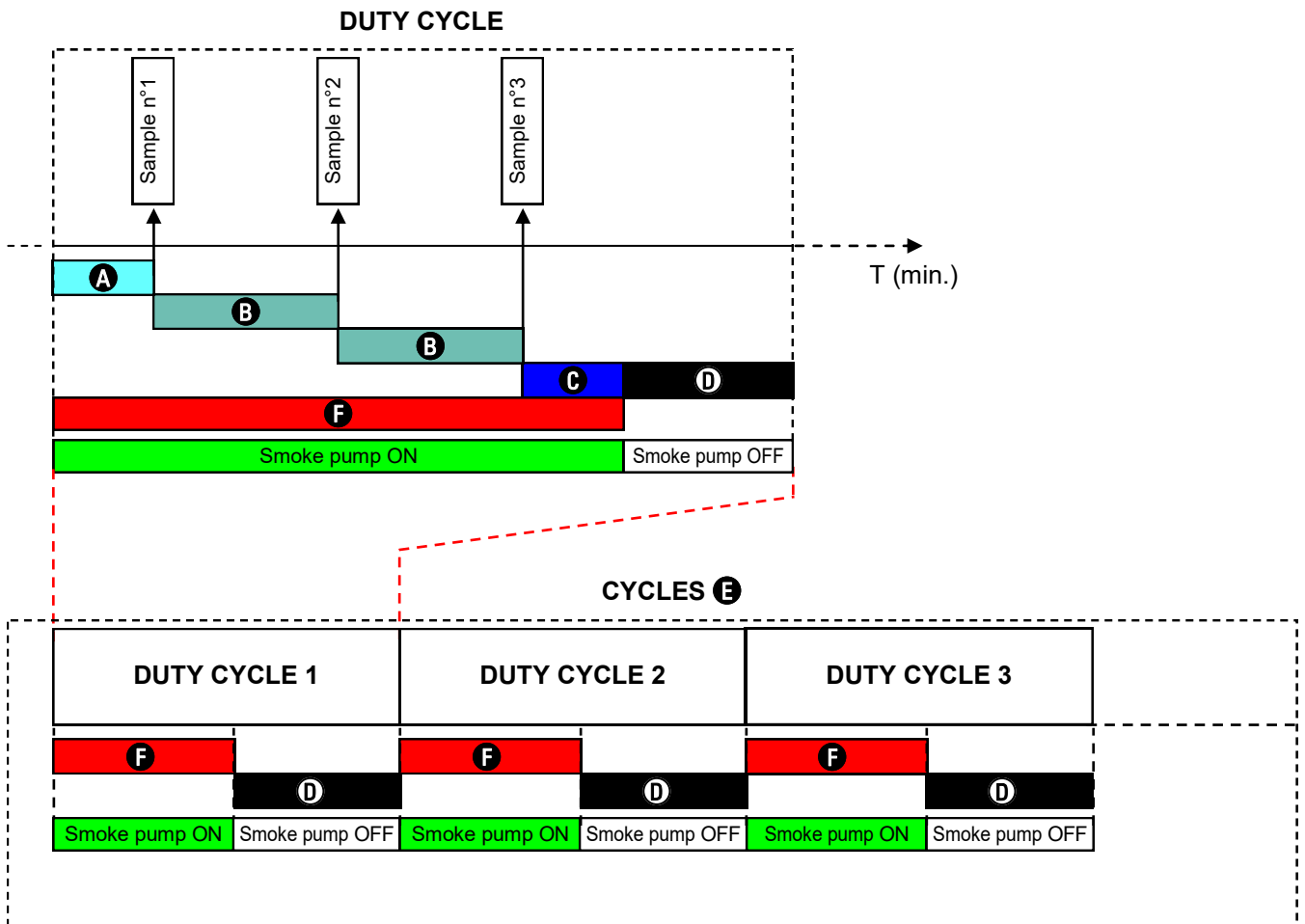

11.3 PERFORMING EMISSION ANALYSIS

By clicking on "Analysis," the instrument displays real-time emission analysis.

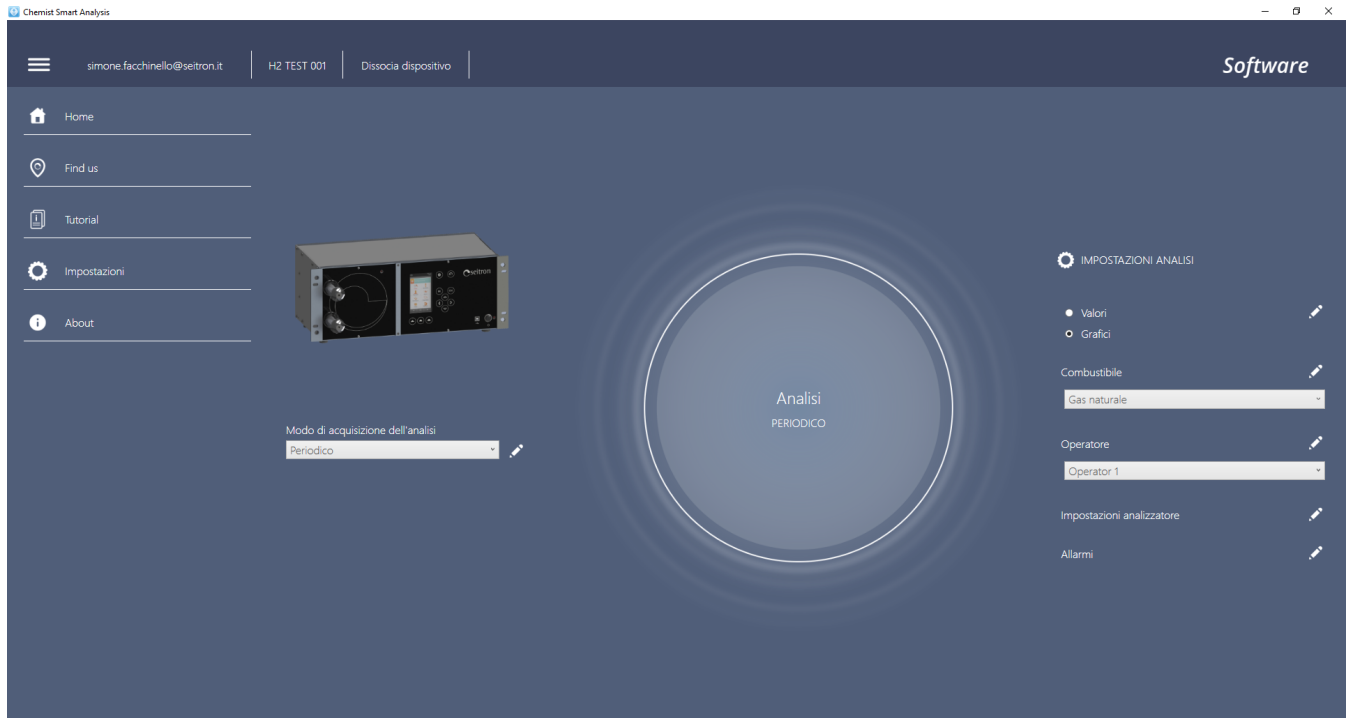

By clicking on the "Start Recording" symbol, the emission analysis begins according to the configuration made; the emission analysis data are recorded in the .csv file.

The toolbar at the top, provides all the information about the stage of analysis that the instrument is performing. It is also possible to follow the analysis progress by means of a configurable graph by clicking on the "Graphs" icon.

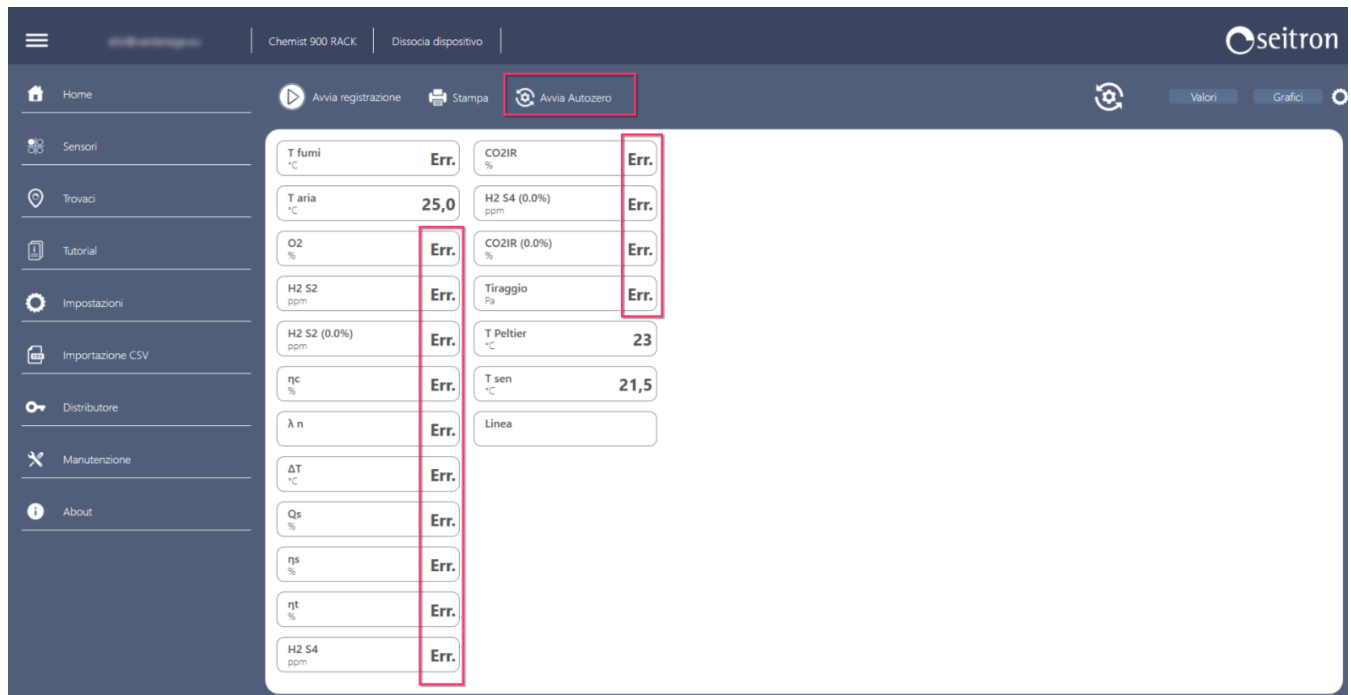

The end of emission analysis will be indicated on the screen by an informative message.

WARNING. If the measurements show an error (Err.), press 'Start Autozero' to resolve it. After pressing 'Start Autozero', the instrument will require a restart. To use the mode without autozero at startup, run the autozero before connecting the Chemist 900 Rack to the PC software. Once you have performed autozero on first startup, connect the instrument to the software to use the available autozero data. This data will be available until a new autozero is run.

12.0 ELECTROCHEMICAL SENSORS

The instrument uses pre-calibrated gas sensors from the Flex-Sensor series. The sensors require no special maintenance, but must be replaced periodically when exhausted. Gas measurements are made with electrochemical sensors that are not subject to natural deterioration because they are inherently free from oxidation processes. Measuring sensors, of the electrochemical type, consist of an anode, a cathode, and an electrolyte solution that depends on the type of gas to be analyzed. The gas penetrates the sensor through a selective diffusion membrane and generates an electric current proportional to the gas absorbed. The current is measured, converted to digital, temperature compensated, processed by the microprocessor and shown on the display. The gas must not be at a pressure that could damage or destroy the sensors; therefore, the suction pump is continuously regulated so as to ensure appropriate flow to the sensors. The maximum allowable pressure is ± 100 hPa.

The details about sensor response time can be found on the table "Measurement and accuracies ranges".



WARNING

Some sensors (for example NH_3 , H_2 , H_2S , SO_2 ,...) are sensible to other gases called interfering gases.

On analysis phase, the influence of interfering gases is compensated only if the corresponding sensors are installed in the instrument.

If a sensor sensitive to NO and NO_2 interfering gases is installed in the instrument, but only the NO sensor is installed in the instrument, NO_2 gas compensation is carried out from the NO_x/NO ratio.

12.1 C_xH_y sensor for measurement of unburned hydrocarbons (pellistor)

Unburned hydrocarbons are chemicals produced by incomplete combustion of molecules (hydrocarbons) made of carbon and hydrogen.

They are usually called by the abbreviation HC or (better) C_xH_y : when the x and y values are substituted for the actual values of the number of C and H atoms, the type of fuel is then exactly defined. In the case of methane, for example, the correct formula is CH_4 . The following table shows the cross-sensitivity of the C_xH_y sensor when exposed to fuels other than methane (CH_4), assumed to be 1.00 for reference.

FUEL	RELATIVE RESULT (relative to Methane)	COEFFICIENT
Ethanol	0.75	1.33
Iso-Butane	0.60	1.67
Methane	1.00	1.00
Methanol	1.00	1.00
n-Butane	0.60	1.67
n-Heptane	0.45	2.22
n-Hexane	0.50	2.00
Propane	0.70	1.43

Calculation example:

Type of fuel: iso-butane
 Relative result: 0.6
 Coefficient: 1.67
 Read value (referring to Methane): 1.34

Value = Read Value x Coefficient

Example: $1.34 \times 1.67 = 2.24$

WARNING

Gas vapors with acidic or silicone compounds (HMDS) irreversibly damage the sensor.

12.2 CO_2 sensor for the measure of carbon dioxide in combustion processes (single NDIR sensor)

Carbon dioxide (CO_2) is the result of the combustion of an organic compound in the presence of sufficient oxygen to complete its oxidation. In nature, it is also produced by aerobic bacteria during the process of alcoholic fermentation and is the by-product of respiration. Many combustion processes are termed 'mixed fuel' and it is therefore difficult to calculate the amount of CO_2 produced. To overcome this drawback, the only way to know the amount of CO_2 produced in a 'mixed fuel' combustion process is to measure CO_2 with special NDIR sensors.

12.3 NH₃ sensor for measuring ammonia in combustion processes



USE ONLY WITH SINTERED STEEL FILTER MOUNTED ON THE SMOKE SAMPLING PROBE TIP AND HDPE FILTER CARTRIDGE INSIDE THE FILTER HOLDER.

This sensor measures the presence of ammonia (NH₃) in flue gases, and since this gas is easily soluble in H₂O, arrangements are needed to make the measurement correctly, which must be made:

- For short periods of time (1-2 hours).
- Using only the flue gas sampling probe (supplied) with the sintered steel filter (to be purchased separately) mounted on the tip, which is suitable for taking this measurement; alternatively, using the flue gas sampling probe for industrial engines (discontinued item) as it has a sintered steel filter on the tip. This filter, creates a dry "pre-filtration" so as to retain the moisture that effectively cancels out the NH₃ content present in the flue gas not making it measurable. The filter being inserted inside the chimney is heated by the flue gases and kept warm; the gas passing through the filter does not form condensation and thus allows accurate measurement of ammonia. The filter inserted into the chimney is called a "hot filter."
- Replace the paper filters in the two condensate traps outside the instrument with HDPE filters (to be purchased separately), which trap dust particles but do not trap residual moisture and thus ammonia.
If the process is not particularly dirty, it is possible to make the measurement with only the stainless steel filter mounted on the tip, removing the two filters on the anti-condensation traps increasing the analysis time to 4 continuous hours.

CAUTION

The NH₃ sensor is sensitive to other gases called interfering gases:

H₂S >10 ppm

SO₂ >10 ppm

NO >10 ppm

If during analysis the influence of the interfering gases present is greater than the indicated value, compensation takes place only if the corresponding sensors are installed on the instrument.

For mounting the sintered steel filter (code AAFS02) on the probe tip, refer to the instructions supplied with the filter.

The procedure for replacing the filters (code AAFA04) in the anti-condensation traps is described below:

- 1** Unscrew the transparent cup.

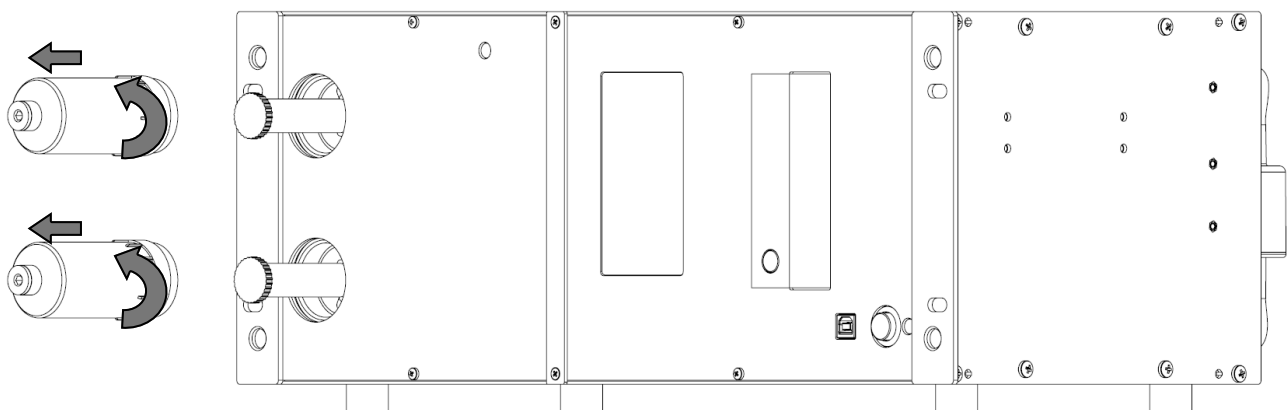

2 Unscrew the dust filter

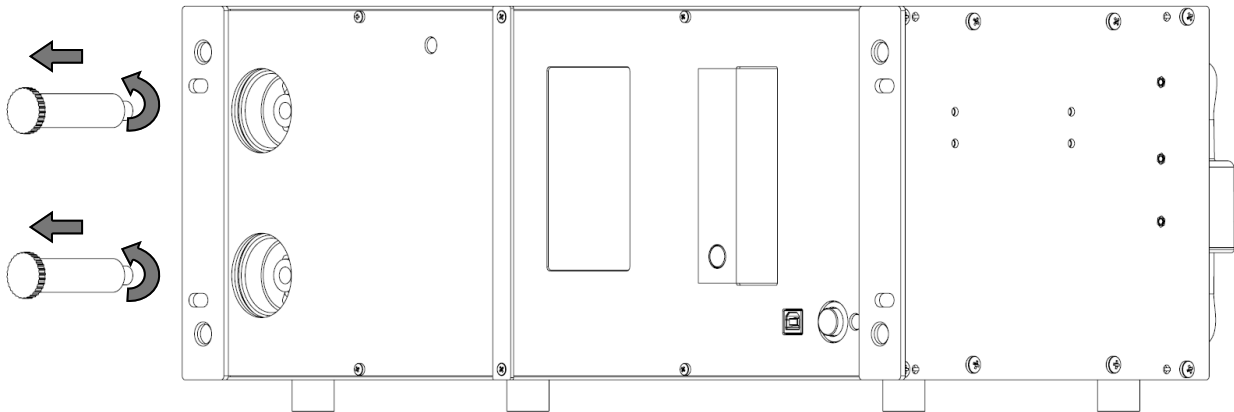

3 Replace the paper filter with the HDPE filter and screw it back into the appropriate seat.

4 Reassemble the filter by doing the reverse operations described so far.

12.4 Life of gas sensors

The gas sensors in this instrument are of the electrochemical type: a chemical reaction takes place inside them in the presence of the gas to be detected, which produces an electric current. The electric current acquired by the instrument is then converted to the corresponding concentration of the gas. The life of the sensor is strongly linked to the consumption of the reagents within it, with the consumption of which the sensor's characteristics degrade until exhaustion, after which replacement is required. To ensure measurement accuracy, sensors must be recalibrated periodically: recalibration can only be performed at a qualified SEITRON AMERICAS service center. Table 12.4 shows the specific information for each sensor.

12.5 Gas sensor life table

CODE	MEASURED GAS	IDENTIFYING COLOR ⁽¹⁾	AVERAGE LIFE	RECALIBRATION
Flex-Sensor O₂ 100% Cod. AACSE81R	O ₂ Oxygen		20,9% vol 72 months 100% vol 15 months	not required
Flex-Sensor O₂ LL Cod. AACSE44	O ₂ Oxygen		48 months	not required
Flex-Sensor O₂ Cod. AACSE15R	O ₂ Oxygen		48 months	not required
Flex-Sensor CO+H₂ Cod. AACSE12	CO Carbon Monoxide	Red	48 months	annual ⁽²⁾
Flex-Sensor CO+H₂ low range Cod. AACSE24	CO Carbon Monoxide	Red	48 months	annual ⁽²⁾
Flex-Sensor CO 100.000 ppm Cod. AACSE17	CO Carbon Monoxide	Purple	48 months	annual ⁽²⁾
Flex-Sensor CO 20.000 ppm Cod. AACSE18	CO Carbon Monoxide	Light blue	48 months	annual ⁽²⁾
Flex-Sensor Dual CO (8000 ppm) - H₂ (2000 ppm) Cod. AACSE79	CO Carbon Monoxide	Red	48 months	annual ⁽²⁾
	H ₂ Hydrogen	Red	48 months	annual ⁽²⁾
Flex-Sensor NO Cod. AACSE10	NO Nitrogen Oxide	Orange	48 months	annual ⁽²⁾
Flex-Sensor NO low range Cod. AACSE25	NO Nitrogen Oxide	Orange	48 months	annual ⁽²⁾
Flex-Sensor NO₂ Cod. AACSE14	NO ₂ Nitrogen Dioxide	White	36 months	annual ⁽²⁾
Flex-Sensor NO₂ low range Cod. AACSE26	NO ₂ Nitrogen Dioxide	White	48 months	annual ⁽²⁾
Flex-Sensor SO₂ Cod. AACSE13	SO ₂ Sulphur Dioxide	Green	36 months	annual ⁽²⁾
Flex-Sensor SO₂ (J57-2017) Cod. AACSE77	SO ₂ Sulphur Dioxide	Green	36 months	annual ⁽²⁾
Flex-Sensor SO₂ low range Cod. AACSE28	SO ₂ Sulphur Dioxide	Green	48 months	annual ⁽²⁾
Flex-Sensor CxHy 0-5.00% vol. ref. at CH₄ Cod. AACSE39	CxHy Unburnt Hydrocarbons		48 months	annual ⁽²⁾
Flex-Sensor CO₂ 0-100% Cod. AACSE47	CO ₂ Carbon Dioxide		>48 months	annual ⁽²⁾
Flex-Sensor H₂S low range Cod. AACSE35	H ₂ S Hydrogen Sulfide		48 months	annual ⁽²⁾
Flex-Sensor H₂S Cod. AACSE72	H ₂ S Hydrogen Sulfide		48 months	annual ⁽²⁾
Flex-Sensor NH₃ Cod. AACSE56	NH ₃ Ammonia		48 months	annual ⁽²⁾
Flex-Sensor H₂ Cod. AACSE78	H ₂ Hydrogen		24 months	annual ⁽²⁾

Note:

(1) Colored dot present on the sensor board.

(2) UNI 10389 - 1 requires that the instrument and sensors must be calibrated in a laboratory authorized to issue calibration certificates once a year.

An infrared bench for gas detection based on infrared spectroscopy (NDIR) can be installed on the S9000-RACK. With this system, one or more of the following gases can be detected simultaneously: CO, CO₂, and CH₄. Along the pneumatic circuit, an additional dust filter is inserted before the IR bench.

The principle is that of non-dispersive IR absorption (NDIR) at 2 wavelengths, stability over time, no interference with other compounds in the process, high response speed and fast return to zero value even after measurements of concentrations up to the maximum measurement limit.

Gases absorb light at particular wavelengths, typically in the IR. An NDIR system includes: an IR light source, a chamber containing the gas sample to be analyzed, and a detector equipped with an optical filter. Light passes through the chamber and the gas sample will absorb it at a specific wavelength (e.g., 4.26µm for CO₂) or on specific bands.

The filter is the nondispersive optical component and allows the detector to uniquely identify the gas based on the trend of the absorption spectrum. The narrower the bandwidth of the filter, the greater the specificity of the sensor. The intensity of light (at a certain wavelength) reaching the detector is inversely proportional to the concentration of the gas in question.

The signal collected by the detector is then processed by the downstream electronics in order to obtain the concentration of CO, CO₂ and/or CH₄ according to the instrument configuration.



WARNING

The CO₂ measurement of the NDIR AACSE38 bench can be linearized in air, nitrogen or without any linearization.

13.1 Infrared bench for heat treatment.

The S9000-RACK can be equipped with an NDIR bench specifically for CO₂ measurement at concentrations below 25000 ppm and with the possibility of setting the interference value according to the H₂ concentration.

Since the measurement of CO₂ in a thermal process is very close to the ambient CO₂ value, it is important that the autozero line is supplied with N₂ gas and **not** ambient air.

14.1 Troubleshooting guide

SYMPTOM	PROBABLE CAUSES AND REMEDIES
The instrument does not work; when pressing the On/Off key, it does not switch on.	<ul style="list-style-type: none"> a. Press and hold the On/Off key down for longer than 2 seconds. b. Check the fuses and replace them, if it is needed. c. The instrument is defective: send it to the service center.
After the instrument turns on, the sensor diagnostic screen displays an error in one or more cells.	Sensor communication error (sensor may be broken or not properly connected) or a change in the sensors installed in relation to the configuration is signaled.
After switching on, the instrument fails to perform the autozeroing.	<ul style="list-style-type: none"> a. If the NDIR bench is installed and enabled, check that the autozero time is set at 70 seconds at least. b. An error has occurred in one or more sensors, see the sensor Diagnostic screen.
In the pressure / draft screen an error is reported to the piezoresistive pressure sensor, compensated for temperature.	There might be a calibration problem. Send the instruments to the service center.
The analysis screen gives a flue gas temperature (Tf) error.	<ul style="list-style-type: none"> a. The thermocouple is not connected; connect the thermocouple to the analyzer. b. The sensor has been exposed to temperatures greater or lower than its operating temperature range. c. The thermocouple is faulty. Send the complete probe to a service center.
On the analysis screen is reported an error on the condensate outlet circuit.	Contact the assistance center.
The "----" icon appears in the analysis screen.	The instrument is unable to calculate the numerical value based on the combustion analysis carried out. When the analyzer detects valid combustion data, the "----" icons are replaced with numerical data.
In the analysis screen, the "----" icon appears next to the gases detected by the NDIR bench.	<ul style="list-style-type: none"> a. Check if the NDIR bench is enabled, then switch off and switch the instrument on again. b. If in "Diagnostic→Bench NDIR→Status Register" the CO₂, CO, CH₄ indicate "invalid", it means that the inlet gas is out of the measurement range. c. If in "Diagnostic→Bench NDIR→Status Register" the Sample Temp. indicates "Out of Range", it means that the measurement temperature (detected in the cell /IR tube) is out of the 0-75°C range or 32-167 °F. d. Warning: in the "Diagnostic→Bench NDIR→Status Register" ignore the messages relating to "Zero Required" and "Proc. In Progress". e. If the problem persists, contact the service center.
"Max. Lim." or "Min. Lim" appears on the analysis screen.	The relevant sensor is detecting a value that is beyond the analyzer measuring range. "Max. Lim" or "Min. Lim." are replaced by numbers when the instrument reveals values that are within the measuring range.

Troubleshooting guide

SYMPTOM	PROBABLE CAUSES AND REMEDIES
The pump does not work or the flow is lower than 1,5l/min.	<ul style="list-style-type: none"> a. The suction flow is blocked. Check that the particulate filter is clean. b. Contact the service center.
The instrument is switched on, but the display seems to be off.	<ul style="list-style-type: none"> a. Check the display brightness level (see the configuration menu). b. If the problem persists, contact the service center.
The heated line is enabled, but the heated tube status displays 'disab. '.	The probe connector is not properly connected to the 'HEATED LINE' connector of the instrument.
T head indicates ' no probe '.	The heated head connector is not properly connected to the 'HEATED HEAD' connector of the instrument.
T tube indicates ' error '.	<ul style="list-style-type: none"> a. The connector may be damaged. b. The cable of the temperature sensor may be damaged. Send it to the service center.
The heated line is enabled, but the tube status and/or the head status and/or Peltier status display ' fault '.	<ul style="list-style-type: none"> a. Check that the T head, T tube and T Peltier temperatures are within the parameters that have been set. b. Contact the service center.
The Cooler is enabled, but the Peltier status indicates ' fault '.	<ul style="list-style-type: none"> a. Check that the T Peltier temperature is within the parameter that has been set. b. Contact the service center.

15.1 Spare parts

CODE	DESCRIPTION
AACCV01	Schuko plug cable.
AACCV04	European plug cable.
AACCV06	US plug cable.
WFILX0016	Anti-cleaning filter for Infrared bank protection.
AAFA02	Filter cartridge, pack of 2 pieces
WFUS5X20004R	4A delayed fuse
WRAC0006901	Male 1/8" GAS BSPP → female Ø 8 mm fitting
WRAC0007001	Male fitting 1/8" GAS BSPP → female Ø 9 mm
WRAC0007201	Male fitting 1/8" GAS BSPP → pipe coupling external Ø 6 mm
WRACO0026	Male fitting M5 → pipe coupling external Ø 4 mm
WRACO0041	Male fitting 1/8" → hose connector Ø 6 mm
WTUB0005301	Polyurethane hose (ø Outer 6mm - ø Inner 4mm).

15.2 Accessories

CODE	DESCRIPTION
AASW17	Configuration software.
AAUA01	USB-A / USB-B adapter cable.
AAFA04	Filtering cartridge HDPE 100um 12x57mm, 2 pieces pack
AASF31	7" flue gas sampling probe with 10 ft cable. Working temperature range: 752°F.
AASF32	12" mm flue gas sampling probe with 10 ft cable. Working temperature range: 1112°F.
AASF35	30" mm flue gas sampling probe with 10 ft cable. Working temperature range: 1472°F.
AASF36	40" mm flue gas sampling probe with 10 ft cable. Working temperature range: 2192°F.
AASJ03	Flue gas suction probe handle; without ferrule - length Cable: 3 meters.
AAPT08	7" rigid tip. Working temperature 752°F – for AASJ03 handle.
AAPT09	12" rigid tip. Working temperature 1112°F – for AASJ03 handle.
AAPT10	30" rigid tip. Working temperature 1472°F – for AASJ03 handle.
AAPT11	40" rigid tip. Working temperature 2192°F – for AASJ03 handle.
AAFS02	Sintered stainless steel filter
AACEX01	10 ft extension cable for gas sampling probe.
AASP01	Heat protection shield for flue gas sampling probes.
AATB01	Cap for the pressure measurement line of the flue gas sampling probes.
AATT01	12" (300mm) "L-Shaped Pitot tube (no thermocouple)".
AATT02	32" (800mm) "L-Shaped Pitot tube (no thermocouple)".

15.3 Service Centers

Headquarters:

Seitron Americas Inc.

140 Terry Drive Suite 101

Newtown, PA 18940 USA

Tel: (215) 660-9777

Fax: (215) 660-9770

Email: service@seitronamericas.com

Web: www.seitronamericas.com

16.1 Routine maintenance

This instrument is designed and manufactured using high-quality components.

Proper and systematic maintenance will anticipate the occurrence of malfunctions and increase the overall life of your instrument.

The basic operations to be performed by the operator are as follows:

- Avoid considerable thermal shock to the instrument before use and, if necessary, wait until the temperature of the instrument is within the parameters of use.
- Avoid vacuuming fumes directly without a dust-condensate trap.
- Do not exceed sensor overload thresholds.
- When the analysis is complete, disconnect the flue gas sampling probe and have the S9000-RACK draw in clean air for 5-10 minutes or at least until the displayed parameters return to their initial state.
- Clean, when necessary, the filter assembly by replacing the dust filter and blowing with air inside the flue gas probe tube to blow out any condensation that has formed.

Do not use abrasive detergents, thinners and other similar cleaning agents to clean the instrument.

16.2 Scheduled maintenance

At least once a year send the instrument to the SERVICE CENTER for a thorough internal review and cleaning. SEITRON highly trained staff is always available for all types of business, technical, application and maintenance information.

The service department is always ready to return the instrument to you as fresh from the factory in the shortest possible time.

Calibrations are performed with gases and instruments referable to National and International Champions.

The annual overhaul, complete with calibration certificate, guarantees perfect operation of the instrument as required by UNI 10389-1, and is essential for users subject to ISO 9000 recognition.

16.3 Cleaning external dust filters

In the event that the dust filters external to the instrument are found to be blackened it becomes necessary to replace them immediately.

- 1 Unscrew the transparent cup.

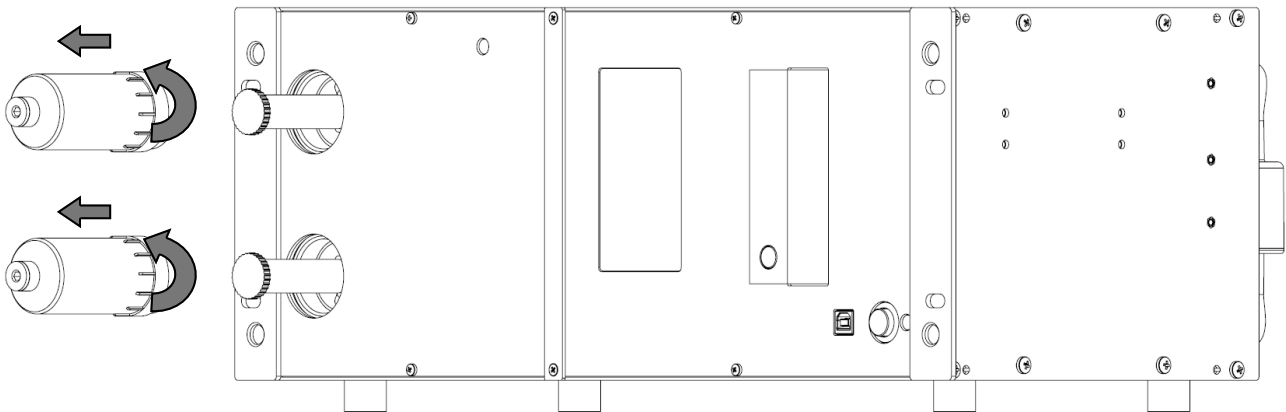

- 2 Unscrew the dust filter.

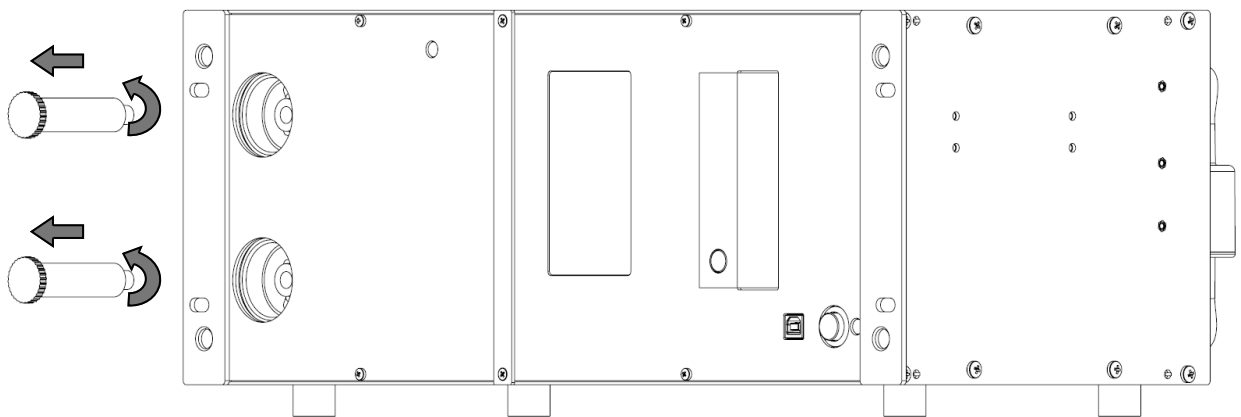

- 3 Clean the inside of the cup using compressed air, soap and water, ultrasonic cleaning (do not use solvents or thinners since the container is made of PVC plastic material).
- 4 Replace the dust filter with a new one.
- 5 Reassemble the filter by doing the reverse operations described so far.

16.4 Replacement of external anti-pollution filter on IR line

In the event that the anti-pollution filter located on the back of the instrument is found to be blackened it becomes necessary to replace it immediately.

- 1 Pull the tubes out of the filter.

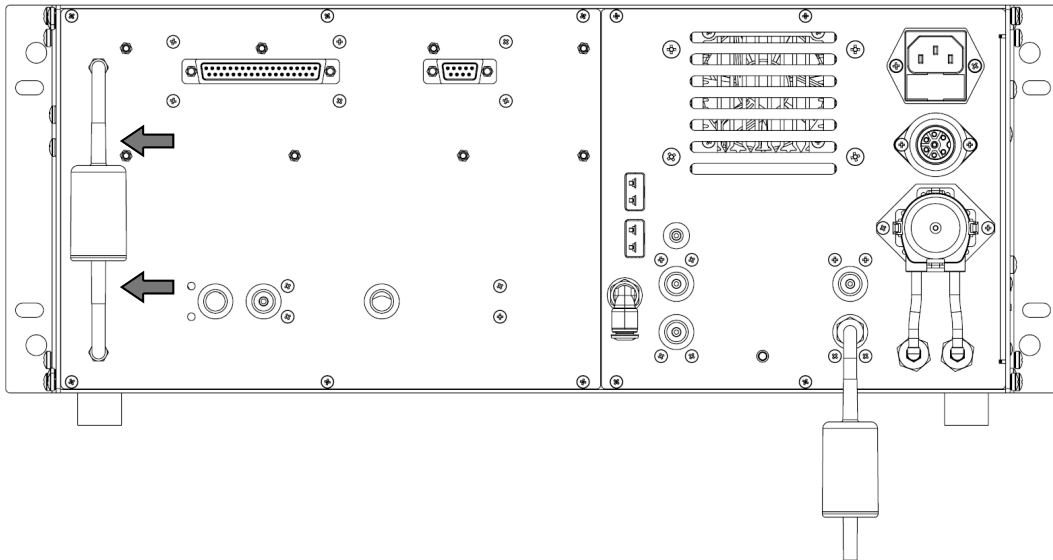

- 2 Replace the dust filter with a new one. See chapter "Replacement Parts."
- 3 Reassemble the filter by doing the reverse operations described so far.

16.5 Replacement of external anti-cleaning filter on remote air intake

In case the anti-cleaning filter located on the back of the instrument is found to be blackened it becomes necessary to replace it immediately.

- 1 Pull the dust filter out of the tube.

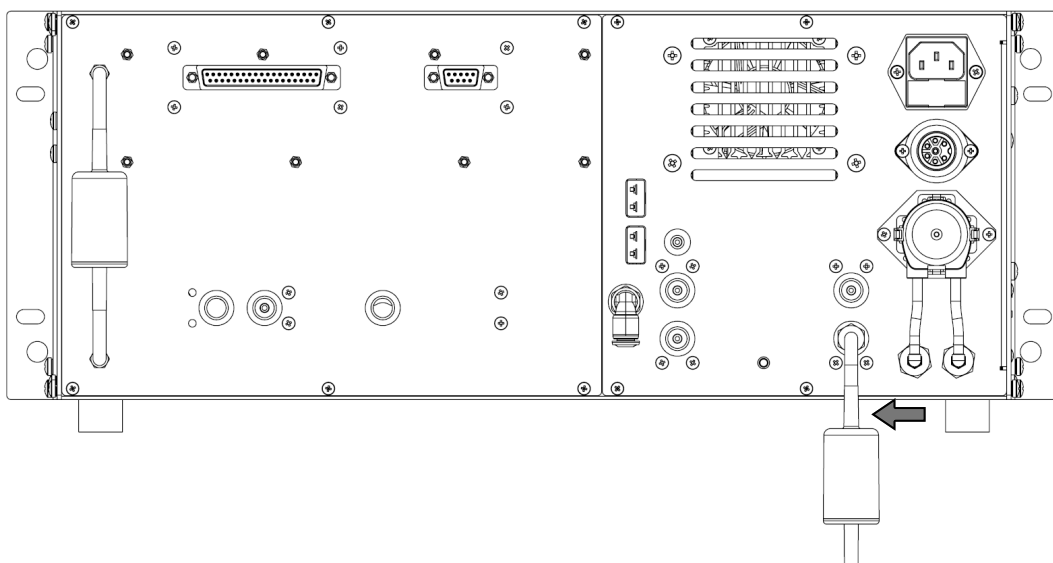

- 2 Replace the dust filter with a new one. See chapter "Replacement Parts."
- 3 Reassemble the filter by doing the reverse operations described so far.

16.5 Fuse replacement

In case it is necessary to replace the instrument fuses, proceed as follows.
For the technical characteristics of the fuses, see chapter ["4.1 Technical features."](#)

- 1 Turn off the instrument and disconnect the power cord from the instrument connector. Locate the fuse drawer and pull it out.



- 2 Pull out the fuses, using a screwdriver, being careful not to damage the fuse box and/or fuses.





16.6 Firmware Update

The manufacturer periodically releases firmware updates of the instrument in order to correct unavoidable mistakes or improve the instrument performance or add new functions. This update can be performed by the user by following the simple instructions below.

Instructions to update the combustion analyzer with a new firmware:

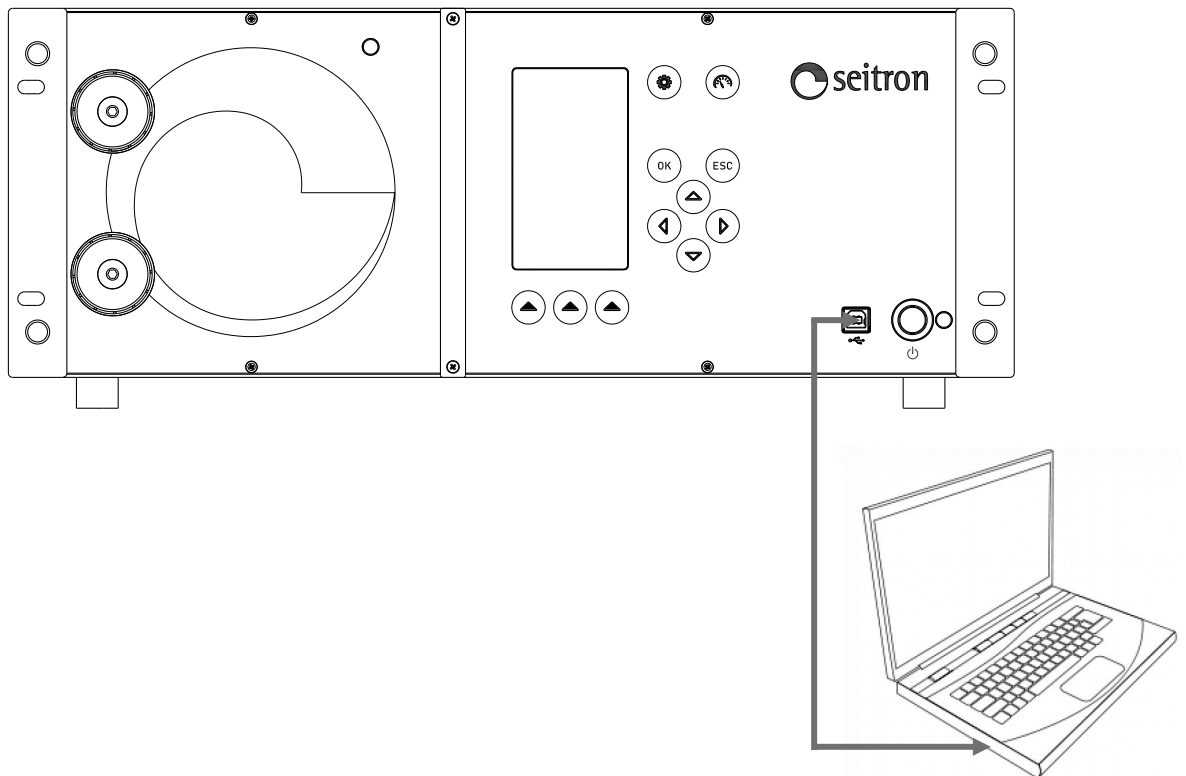

1. Log in to the website www.seitronamericas.com and download the firmware file available in the "combustion analyzers" section. This file is in a compressed version .zip.
2. Unzip the file thus obtaining the contents of the .zip file (extension .srec).
3. Plug in the analyzer to the PC via the USB cable.
4. Connect the analyzer to the mains supply using the cable with the IEC C14 socket supplied.
5. Press and hold the ON/OFF key of the combustion analyzer for approx. 10 seconds.
6. Release the ON/OFF key; the red led turns on steady.
7. Press and hold the ON/OFF key until the red led turns off.
8. Release the ON/OFF key; the red led turns on flashing slowly (1 flash/second).
9. The analyzer will be recognized by the operating system as a portable device drive.
10. Copy the firmware file (extension .srec) to the directory of the analyzer.
11. The red led blinks quickly to indicate that the firmware is being updated; wait till the end of the file copy operation.
12. The red led is steady on.
10. The file copy directory will be closed and the analyzer will restart.
11. The analyzer is now updated, it can be powered off and it can be unplugged from the PC.

Fuel Coefficients and Formulas

The following table, derived from UNI 10389-1, shows the coefficients of stored fuels which are used to calculate losses and efficiencies.

Fuel coefficients for calculating combustion efficiency									
Fuel	A1	A2	B	CO ₂ t (%)	PCI (KJ/Kg)	PCS (KJ/Kg)	M air (Kg/Kg)	M H ₂ O (Kg/Kg)	V gas dry (m ³ /Kg)
Natural gas	0,0280	0,380	0,0100	11,70	50050	55550	17,17	2,250	11,94
#2 Oil	0,031	0,479	0,0066	15,70	42900	45700	14,3	1,136	10,34
#4 Oil	0,031	0,484	0,0066	15,80	41100	43500	13,8	0,973	10,06
#6 Oil	0,035	0,551	0,0048	16,00	39800	42200	13,61	0,981	9,97
Diesel	0,031	0,500	0,0066	15,70	42900	45700	14,3	1,136	10,34
Wood/Pellets 8% (RH)	0,035	0,670	0,0071	19,01	18150	19750	6,02	0,660	4,58
Coal	0,032	0,595	0,00	18,60	31400	32300	10,70	0,370	8,14
Bio-Fuel 5%	0,031	0,804	0,0066	15,70	42600	45400	14,22	1,133	10,64
Bagasse	0,040	0,691	0,0219	20,45	6950	8830	2,50	0,779	1,93
Butane	0,028	0,380	0,0073	14,00	45360	49150	15,38	1,548	10,99
Propane	0,028	0,388	0,0073	13,7	45950	49950	15,61	1,638	11,11
Bio-Fuel 20%	0,0313	0,486	0,0052	15,52	41806	44620	14,04	1,152	13,89
Digester gas	0,030	0,318	0,0076	10,65	21303	23644	6,93	0,905	7,02
B100	0,031	0,486	0,0053	15,77	37864	40528	12,50	1,08	12,42
B80	0,0307	0,00	0,0056	15,76	38872	41562	12,86	1,091	12,01
B50	0,0307	0,00	0,008	15,73	40382	43114	13,40	1,108	11,38
LNG	0,0312	0,00	0,008	11,00	49232	54610	18,14	2,202	16,93
Kerosene	0,031	0,00	0,0053	15,25	43500	46500	14,58	1,224	14,36

Details of the coefficients of the fuels:

- **CO₂ t:** The value of CO₂ generated by combustion in stoichiometric condition, i.e. without excess Oxygen and therefore maximum.
- **A1, A2, B:** Also please have a look at the Siegert formulas from the European standard EN50379-1 (in the following).
A1 is the parameter in the Siegert Formula when the O₂ measurement is available.
A2 is used when the CO₂ measurement is available.
Note: - Please also consider that in the U.S. usually the A1 parameter is the same as the 'European' A1 BUT divided by 2.
- For Germany coefficients A1 and A2 are swapped.

Flue gas heat losses are calculated from measured oxygen content according to the relationship:

$$q_A = (t_A - t_L) \times \left(\frac{A1}{21 - O_2} + B \right)$$

Flue gas heat losses are calculated from measured carbon dioxide content according to the relationship:

$$q_A = (t_A - t_L) \times \left(\frac{A2}{CO_2} + B \right)$$

Air index is calculated with the formula:

$\lambda = 21 / (21 - O_2)$, where O₂ is the oxygen residual concentration in the combustion smokes.

Air excess is calculated with the formula:

$$e = (\lambda - 1) * 100$$

- **CO conv:** Conversion coefficient from ppm to mg/KWh. It can be expressed as a function of the gas density (CO in this case) and the volume of the dry smoke.
- **NO conv:** Same as CO conv, but for NO.
- **NOx conv:** Same as CO conv, but for NOx.
- **SO₂ conv:** Same as CO conv, but for SO₂.
- **PCI:** Potere Calorifico Inferiore. Italian for LHV (Lower Heating Value).
- **PCS:** Potere Calorifico Superiore. Italian for HHV (Higher Heating Value).
- **m H₂O:** Mass of the air produced (per each Kg of fuel) in the combustion in stoichiometric condition.
- **m Air:** Mass of the air needed for combustion in stoichiometric condition.
- **V g.d.:** Volume of dry smokes produced in the combustion.

Flue gas analysis according to Italian Law No. 10/1991 and subsequent modifications and supplements, Legislative Decree 192/2005 and the UNI 10389-1 standard

Preamble

It is Seitron intention, by means of this compact guide, to provide boiler installers/service technicians with a quick and easy way to understand whether a boiler conforms to the requirements of Italian Law no. 10 dated January 1991, and subsequent modifications and supplements, and Legislative Decree 192/2005. The contents of this guide have been extremely simplified whereby they are not to be deemed at all comprehensive of the complex phenomenon of combustion.

Flue Gas Analysis: theory

During the combustion process taking place in a boiler, part of the heat evolved by the burner is transferred to the water or air to be heated. The quantity of heat available at the burner is called the input rating (Pf) and is usually declared by the boiler manufacturer. Part of this energy, known as the useful output (Pu), is used by the boiler. The remainder is lost to the flue gas in the stack and is known as Stack loss (Qs).

Thus we can say that: $Pf = Pu + Qs$

THE THERMAL EFFICIENCY OF COMBUSTION is given by:

$$\eta = 100 - Qs$$

According to the Italian Legislative Decree 192/2005 the MINIMUM thermal efficiency η should respect the values below:

For hot water generators:

Period of installation	Minimum efficiency %	Minimum with Pn < 35 kW
Before 29/10/1993	$84 + 2 * \log Pn - 2$	around 85 %
From 29/10/1993 to 31/12/1997	$84 + 2 * \log Pn$	around 87 %
From 01/01/1998 to 07/10/2005	Standard boilers $84 + 2 * \log Pn$	around 87 %
	Low temperature boilers $87.5 + 1.5 * \log Pn$	around 90 %
	Condensing boilers $91 + 1 * \log Pn$	around 92.5 %
After 08/10/2005	Condensing boilers $90 + 2 * \log Pn - 1$	around 92 %
	Other boilers $88 + 2 * \log Pn - 1$	around 90 %

For hot water generators:

Period of installation	Minimum efficiency %	Minimum with Pn < 35 kW
Before 29/10/1993	$83 + 2 * \log Pn - 6$	around 80 %
After 29/10/1993	$84 + 2 * \log Pn - 3$	around 83 %

Stack loss is calculated by applying a simple formula which relates it to other easily measurable parameters:

$$Qs = \frac{A2}{CO_2} + B \quad Tf - Ta$$

Where: A2, B = factor that depends on the fuel used
 Tf = flue gas temperature
 Ta = combustion air temperature
 CO₂ = % carbon dioxide in the flue gas

Thus in order to calculate the stack loss and hence the thermal efficiency of a plant, one must measure the two temperatures (flue gas and air) and the level of carbon dioxide contained in the flue gas (% CO₂). These operations are performed automatically by the flue gas analyzer during testing.

Optional measures list which the instrument can perform, if properly set:

MEASURE	DEFINITION
λ, n	Air index (defined as λ , sometimes also indicated as n).
e	Air excess. Expressed as a percentage according to the formula in the appendix B, is the ratio between the volume of air actually entering the combustion chamber and the one theoretically needed.
T smoke (T1)	Smoke temperature , detected by the probe linked to connector T1.
T air (T2)	Combustion air temperature , detected by the probe linked to connector T2.
T Peltier	Peltier condensation cells temperature.
T tube	Heated tube temperature.
ΔT	Differential temperature: It is the difference between the smoke temperature and the air combustion temperature.
Q_s (LHV)	Stack losses in relation to the Lower Heating Value: It is the percentage of dissipated heat through the stack referred to the lower heating value (LHV)
η_s (LHV)	Sensible efficiency in relation to the Lower Heating Value: It is the burner efficiency calculated according to the UNI 10389-1 standard, as the ratio between conventional heating power and the burner heating power. Among the combustion losses, only the sensible heat lost with flue gasses is taken into account, thus neglecting the radiation losses and incomplete combustion losses. This value is referred to the Lower Heating Value (LHV) of the fuel and cannot exceed 100%. The sensible efficiency value is to be compared against minimum efficiency stated for the heating system performances.
η_c (LHV)	Condensation efficiency in relation to the Lower Heating Value: Efficiency deriving from the condensation of water vapor contained in flue gases, calculated according to the UNI 10389-1 standard, and it is referred to the LHV.
η_t (LHV) $\eta_t = \eta_s + \eta_c$	Total efficiency in relation to the Lower Heating Value: Total efficiency. It is the sum of sensible efficiency and condensation efficiency. It is referred to LHV (Lower Heating Value) and can exceed 100%.
Q_s (HHV)	Stack losses in relation to the Higher Heating Value: It is the percentage of dissipated heat through the stack referred to the higher heating value (HHV)
Q_t (HHV)	Total stack losses: It is the total heat percentage dissipated through the stack.

MEASURE	DEFINITION
η_s (HHV)	<p>Sensible efficiency in relation to the Higher Heating Value:</p> <p>It is the burner efficiency calculated as the ratio between conventional heating power and the burner heating power. Among the combustion losses, only the sensible heat lost with flue gasses is taken into account, thus neglecting the radiation losses and incomplete combustion losses. This value is referred to the Higher Heating Value (HHV) of the fuel and cannot exceed 100%. The sensible efficiency value is to be compared against minimum efficiency stated for the heating system performances.</p>
η_c (HHV)	<p>Condensation efficiency in relation to the Higher Heating Value:</p> <p>Efficiency deriving from the condensation of water vapor contained in flue gases referred to the HHV.</p>
η_t (HHV)	<p>Total efficiency in relation to the Higher Heating Value:</p> <p>Total efficiency. It is the sum of sensible efficiency and condensation efficiency. It is referred to HHV (Higher Heating Value) and can not exceed 100%.</p>
Draft	Stack draft measurement.
T sen	Sensor compartment temperature.
Pump capacity	Smoke pump capacity.
PI	<p>Poison Index (CO/CO₂ ratio):</p> <p>It is defined as the ratio between CO and CO₂ useful to determine whether the system needs maintenance.</p>
Pressure	Pressure measurement through P+ and P-.
Velocity	Gas speed, detected by the Pitot tube.
NOx	Measure of nitrogen oxides quantity; the measurement unit can be set in the special menu.
NOx ppm *	Measure of nitrogen oxides quantity; the measurement unit can not be set but it is fixed in ppm.
NOx (rif. O ₂)	Measure of nitrogen oxides quantity referring to O ₂ ; the measurement unit can be set in the special menu.
NOx (rif. O ₂) ppm *	Measure of nitrogen oxides quantity referring to O ₂ ; the measurement unit can not be set but it is fixed in ppm.
CO	CO quantity measurement. Measurement units: ppm - mg/m ³ - mg/kWh - g/GJ - g/m ³ - mg/kWh - % - ng/J
CO (RIF)	CO quantity measurement with O ₂ reference. Measurement units: ppm - mg/m ³ - mg/kWh - g/GJ - g/m ³ - g/kWh - % - ng/J
CO ₂ IR	If the instrument is equipped with the AACSE38 infrared bank, both the calculated CO ₂ measurement and the measurement detected by the IR sensor can be displayed simultaneously.

* : Valid for Piemonte region only (Italy only).



OTHER THAN THE MEASUREMENT LIST ABOVE, IT IS POSSIBLE TO VISUALIZE THE MEASURE OF THE DETECTED GAS ALSO IN PPM, DEPENDING ON THE KIND OF MEASUREMENT CELL IN THE INSTRUMENT. IF IT IS NECESSARY TO MEASURE THE VALUE OF GAS WITH TWO DIFFERENT MEASUREMENT UNITS, SELECT IN THE MEASUREMENTS LIST THE DESIRED GAS IN PPM AND CHANGE THE MEASUREMENT UNIT FOR THE SAME GAS IN THE "CONFIGURATION->ANALYSIS->MEASUREMENT UNIT" SCREEN. NOW THE INSTRUMENT ACQUIRES THE MEASURE WITH TWO DIFFERENT UNITS (PPM AND THE ONE PREVIOUSLY SET).

WARRANTY

The user is guaranteed against the product's defects of conformity according to European Directive 2019/771 as well as the Seitron Americas warranty terms, available online on the website www.seitronamericas.com. We invite the user to visit our website and check the latest version of technical documents, manuals and catalogs.

Seitron Americas Inc.
140 Terry Drive Suite 101 Newtown, PA 18940 - USA
Tel: (215) 660-9777 Fax: (215) 660-9770
service@seitronamericas.com - www.seitronamericas.com